

X
(E/CEPAL/Conf. 73/S/S No. 22)

BIBLIOTECA NACIONES UNIDAS MEXICO

REQUIREMENTS AND METHODOLOGY FOR THE MASSIVE
IMPLEMENTATION OF SMALL HYDRO POWER STATIONS
IN LATIN AMERICA

SEPTEMBER 1980 VERSION

OLADE'S REGIONAL SHPS PROGRAM

REQUIREMENTS AND METHODOLOGY FOR THE MASSIVE IMPLEMENTATION
OF SMALL HYDRO POWER STATIONS IN LATIN AMERICA

This document was prepared within the framework of activities of the Third Work Group on SHPS (Development of SHPS), organized by OLADE and having as its participants:

ENRIQUE INDACOCHEA R. DE S.
(Group Coordinator)

Coordinator of Transfer of Technology
and Head of the Regional SHPS Program
Latin American Energy Organization
(OLADE)

OSCAR CHAQUEA B.

Advisor to the Mariano Ospina Pérez
Foundation and SHPS Projectionist
Bogotá, Colombia

LUIS EDUARDO MACHADO H.

Professor of Hydraulic Resources at
the National University and SHPS Con-
sultant and Projectionist
Bogotá, Colombia

ROBERTO ENRIQUE VARGAS D.

In charge of the Energy Sector of the
Department of Infrastructure in the
National Politico-Economic Planning
Office (OFIPLAN), San José, Costa Rica
Secretary of the Technical Advising
Group on Energy, Executive Committee,
La Habana, Cuba

MARIO FLEITES D.

Member of the Department of Minor Sys-
tems of the Executing Unit for the
National Rural Electrification Plan
Ecuadorian Institute of Electrifica-
tion, Quito, Ecuador

EFRAIN ENRIQUEZ CH.

FLAVIO FERRAN R.

Researcher for the Division of Engi-
neering Studies, Institute of Electric
Research, Cuernavaca, Morelos, Mexico
Member of the Commission for the SHPS
Program, Sectorial Planning Office,
Ministry of Energy and Mines (MEM),
Lima, Peru

LUIS A. HARO Z.

Energy Specialist, Representative of
the Inter-American Development Bank
(IDB), Bogotá, Colombia.

REQUIREMENTS AND METHODOLOGY FOR THE MASSIVE IMPLEMENTATION OF SMALL HYDRO
POWER STATIONS IN LATIN AMERICA.

INDEX

1. INTRODUCTION
2. SUMMARY
3. REGIONAL PANORAMA
 - 3.1. CURRENT SITUATION
 - 3.2. PERSPECTIVES AND PROBLEMS
4. PLANNING
 - 4.1. DEVELOPMENT POLIICES
 - 4.2. EVALUATION OF RESOURCES AND DEMAND: SCOPES AND METHODOLOGY
 - 4.3. PLANS AND PROGRAMS: FOCUS AND METHODOLOGY
 - 4.4. INSTITUTIONAL ASPECTS
5. STUDIES AND FINANCING
 - 5.1. REQUIREMENTS AND SCOPES OF THE SPECIFIC PROJECT STUDIES
 - 5.2. REQUIREMENTS FOR INVESTMENT AND FINANCING
 - 5.3. TECHNOLOGICAL CONSIDERATIONS
6. CONSTRUCTION
 - 6.1. METHODS, EQUIPMENT, AND INSTALLATION
 - 6.2. CAPACITY FOR EXECUTION AND COMMUNITY PARTICIPATION
 - 6.3. COSTS
 - 6.4. STARTING UP
7. OPERATION AND MAINTENANCE
 - 7.1. INSTITUTIONAL ASPECTS AND RATES
 - 7.2. OPERATION METHODS AND OPERATORS
 - 7.3. UTILIZATION OF ENERGY GENERATED
 - 7.4. MAINTENANCE AND REPAIR
 - 7.5. USE OF THE WATER
 - 7.6. COSTS OF OPERATION
8. TRAINING
 - 8.1. ENGINEERS AND TECHNICIANS
 - 8.2. PERSONNEL FOR CONSTRUCTION, OPERATION, AND MAINTENANCE

APPENDICES:

- I. FORM FOR THE SHPS DATA SHEET (consolidated from every country)
- II. FORM FOR SUMMARY SHEET FOR NATIONAL SHPS SURVEYS
- III. FORM FOR DATA FOR THE IDENTIFICATION OF ISOLATED CENTERS AND MICROREGIONS
- IV. REQUIREMENTS FOR A FORM FOR THE INVENTORY OF CAPACITIES FOR ENGINEERING AND EXECUTION OF PROJECTS
- V. TERMS OF REFERENCE FOR AN ORIENTATION GUIDE FOR THE ELABORATION AND EVALUATION OF SHPS PROJECTS
- VI. TERMS OF REFERENCE FOR A MANUAL FOR THE ELABORATION OF ENGINEERING PROJECTS IN LATIN AMERICA
- VII. TERMS OF REFERENCE FOR A MANUAL FOR THE EVALUATION OF SMALL-SCALE HYDROENERGY RESOURCES AND RURAL ENERGY DEMAND IN LATIN AMERICA
- VIII. IDENTIFICATION OF PRODUCTIVE ACTIVITIES IN THE RURAL AREA WHICH COULD UTILIZE THE ENERGY GENERATED BY SHPS
- IX. REGIONAL COURSES FOR SPECIALIZATION IN SHPS
- X. GUIDELINES FOR THE OPERATORS TRAINING COURSES

1. INTRODUCTION

The Small Hydro Power Stations (SHPS) are one of the principal alternatives for energy development in the Latin American rural area, given the abundance of small-scale hydro resources available in the region.

Even though there is accumulated experience in Latin America dating back to the last decades of the nineteenth century, the development of SHPS has been characterized by sporadic and little systematic actions. Several years ago, it underwent a regressive process in favor of the options of interconnections and generation by means of groups of thermal electro-gens, alternatives which are now beginning to encounter new limits for their application; for the former, with respect to the high cost of transmission lines and substations for isolated areas, and for the latter, with respect to the cost of fuels, maintenance, and logistical difficulties which seriously question the prospects for the installation of thermo-electric generating groups in many isolated settlements.

The development of SHPS will have a significant impact in the degree that it is promoted with massive implementation criteria permitting progressively greater scaled economies and justifying a group of diverse actions for attacking the problem simultaneously on its various fronts, with the planning, evaluation of resources and demand, elaboration, financing and execution of specific projects, the use of water, operation, and maintenance of SHPS and their related institutional aspects, along with matters related to development and the transfer of technology, and the manufacturing and supply of equipment and materials.

In August 1979, OLADE organized the First Meeting of the Work Group on SHPS, which prepared a document later to be titled "The Development of Small Hydro Power Stations in Latin America;" therein, the guidelines were proposed for a regional development strategy, actions were defined for the regional SHPS program, and a system of classification was adopted- and also used in the present document- consisting of denoting the group of stations with installed power ranges up to 5000 kW as "Small Hydro Power

Stations," and the subdivisions were termed in the following way: Micro Hydro Power Stations (less than 50 kW), Mini Hydro Power Stations (50-500 kW), and Small Hydro Power Stations, as a particular term as well as the generic one (500-5000 kW).

In the same document, actions to be realized were grouped into two main areas, the first being termed "Technology and Equipment" and the second, "Development of SHPS."

In April 1980, the Second Work Group on SHPS met and prepared the document "Situation and Prospects for the Technology and Equipment for Small Hydro Power Stations in Latin America," in which actions oriented to the promotion of technological development, the transfer of technology, and the production of equipment and materials for SHPS in the region are recommended.

The present document pretends to establish some guidelines related to the development of SHPS with respect to investment projects, planning, evaluation of resources and demand, studies and financing, the application of non-conventional technologies, construction, operation, maintenance, and training.

In each one of the chapters, an attempt is made to define guidelines for methodologies and concrete actions which could be adopted by the countries of the region in order to promote the development of SHPS. Even though many common elements exist among the countries of the region, marked differences also exist, with respect to economic structure, the degree of socio-economic development, availability of hydroenergy resources and energy needs in the rural area, prospects for the development of alternative energy sources, the availability and potential capacity of a supply of equipment and materials, as well as development policies and the degree of progress and priority assigned to the development of SHPS in the context of the national plans.

Despite the differences pointed out in the previous paragraph, recommendations of a general nature are made, though they will require particular adaptations for the conditions of each country.

In addition, each chapter identifies and proposes regional actions which could be developed by the Latin American Energy Organization (OLADE) and which would be useful for the group of countries in the region; many of these activities will require broader work, given that this document only pretends to define the scopes and terms of reference for their elaboration.

Even though the development of SHPS in each country should have a progressive nature, including actions of modest reaches in the initial stages, its future projection should have a character tending towards MASSIVE IMPLEMENTATION, if it is pretended that the SHPS constitute one of the principal responses to the development needs of the rural area.

Nevertheless, in order to propose intensive development of the SHPS, it is necessary to overcome the two main obstacles presented due to the elevated requirements of per unit investment and some negative experiences with regard to the continuity of operation of small, isolated energy systems, derived from maintenance problems. In Figure No. 1, a block diagram is presented, wherein the previously described situation is illustrated; its principal causes, and a synthesis of the solutions that may be adopted can also be appreciated, the aspects of the technology and equipment for these having been analyzed in the document "Situation and Prospects for the Technology and Equipment for Small Hydro Power Stations in Latin America," prepared by the Second Work Group on SHPS, and the aspects of their implementation, principally with respect to planning, project elaboration, application of non-conventional technologies, and, above all, institutional and organizational matters permitting the application of schemes which assure the operational continuity of the stations, appearing herein.

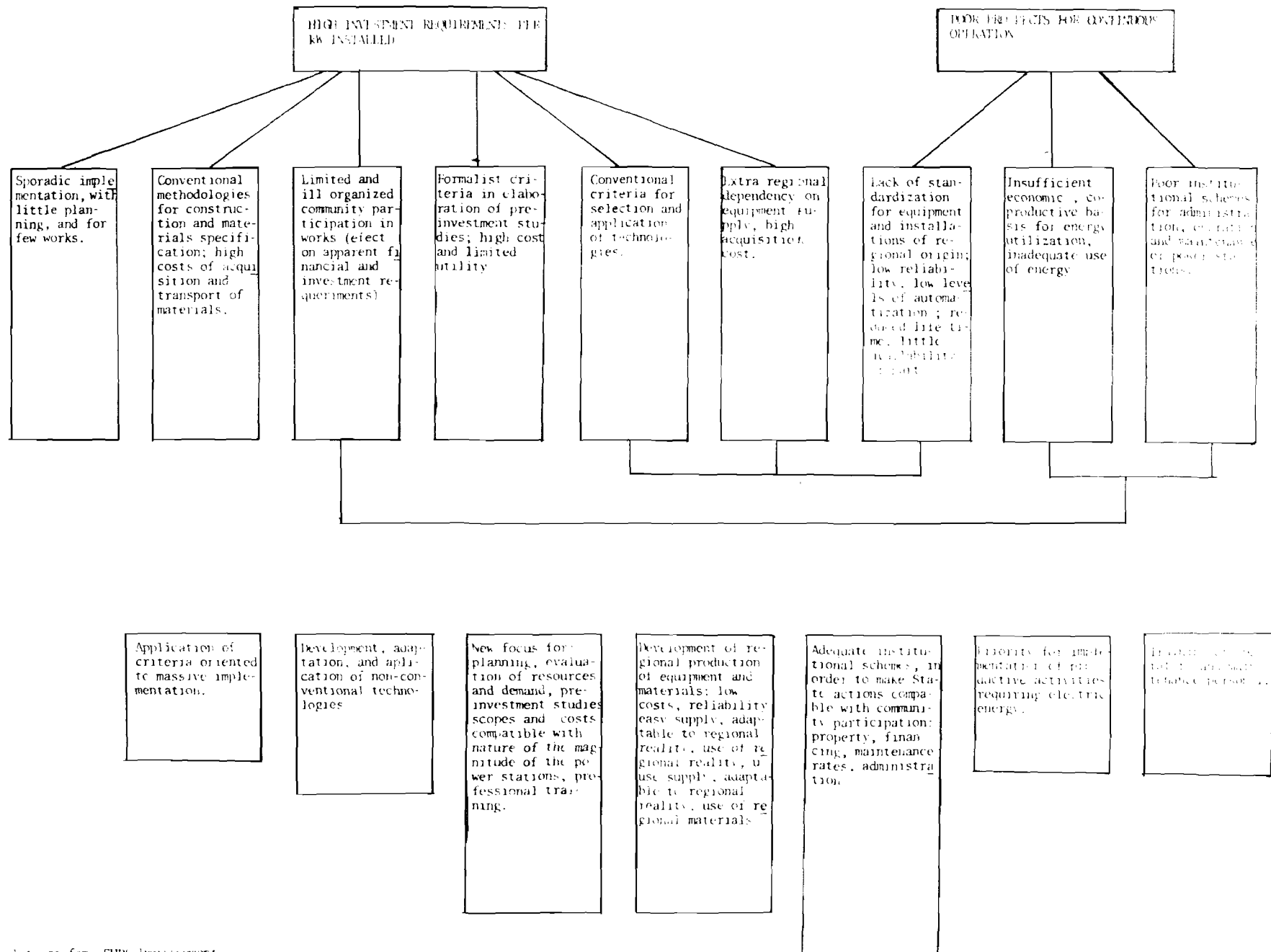

2. SUMMARY

The regional panorama with respect to the Development of SHPS shows that despite the fact that the countries of the region have abundant hydro-energy resources and that the development of this kind of station presents numerous advantages as one of the solutions to the socio-economic problems of the rural communities, only three Latin American countries have been detected as having planned the massive installation of SHPS. Likewise, the numerous stations included within the range of SHPS classifications and installed in the countries of the region, have, in most cases, been constructed without community participation, with conventional technologies, and equipment provided by extra-regional countries.

This indicates the lack of policies and the need for institutional organization to promote the development of SHPS in a planned and coherent way, and in accordance with the reality of the economic and technical resources available. In this regard, a strategy for the massive development of SHPS is put forth, composed of the execution of activities tending to eliminate the existing limitations and the execution of SHPS construction programs in the region, gradually incorporating the results obtained without compromising the accomplishment of the final goals.

The execution of a chronogram for the massive development of SHPS in the region should consider the development of technological research activities and the incorporation of local labor, taking full advantage of the materials of the region. With that, technological dependency and installation costs can be reduced, and professional preparation is increased.

Considering the aforesaid, the following policies are proposed for the massive development of SHPS: institutional policy for rural energy development, for construction, for financing, for technology for the equipment and materials, for training, and for electricity rates.

Likewise, it is necessary to be aware of the available hydro resources, for which a scheme for the evaluation of resources and demand is proposed,

consisting of the identification of the existing and projected SHPS, the evaluation of the resources by basins and watersheds, the preliminary identification of isolated centers and microregions, the establishment of preliminary priorities for those isolated places and microregions susceptible to electrification by SHPS, the verification of the basis for the establishment of the preliminary priorities, and the readjustment of these on the basis of the previous information.

It is considered useful for the countries to have a governmental organism exclusively dedicated to promoting and coordinating the development and implementation of the SHPS and with qualified personnel having clear knowledge of the project's original concepts. Among this organism's tasks would be the gathering of as much information as possible, the development of technology, the planning and construction of SHPS, the coordination of common action, the training of personnel, the organization of the operation and maintenance of the SHPS, the processing of different kinds of financing, the negotiation of the acquisition of equipment and technologies available in the region, the acquisition of cooperation and technical assistance, and finally, the lending of continuity to the construction of stations, training, and the motivation of the communities.

When the plans and programs for the development and installation of the SHPS and training have been formulated, the available financial and technical resources must be taken into account, along with the results of the different programs to be developed. Likewise, the necessities of equipment, labor, professional and technical personnel must be defined.

The planning and programming methodologies should be uniform, and the criteria for the establishment of priorities to be adopted should be in accordance with the policies that are proposed.

In the specific SHPS projects, the studies should refer to an analysis of basins and sub-basins, with hydrological, geological, geomorphological and geotechnical studies, whose degree of depth is in relation to the magnitude of the investment. Similarly, the degree of detail in some cases

will include economic pre-feasibility by means of an indirect analysis of the rates possibilities. The projects presenting doubtful situations with respect to the decision to continue with the studies should be subjected to a feasibility study .

The schemes or pre-designs should permit a quantitative or comparative analysis in economic terms for the feasibility study, in relation to the other alternatives from other sources to satisfy the demand.

The purpose of the studies should consist of the determination of the demand and its variation with time, the available falls, the variation in flows, and their relationship to demand.

For the development of SHPS projects, considerable support is required from each country's national budget, taking into account that SHPS generally serve communities with reduced economic capacities. This makes it necessary to maximize the use of the energy generated, especially in the field of production.

With respect to the cost per kilowatt installed for the SHPS, the objective has been considered as falling between U.S.\$1000 and \$2000, at 1980 costs. In order to attain that objective, it is necessary to begin regional research activities which reduce the costs of engineering and equipment; the greatest participation possible of national engineering in the studies and construction for SHPS should be fomented, and the effective participation of the rural communities in the construction stage should be coordinated through the establishment of electrification committees. Likewise, it will be very important to create the financial funds for the development of rural electrification as considered in the development of the SHPS.

The operation and maintenance of SHPS can have distinct modalities depending on the locale, the kind of control of the station, and each country's institutional system. It is recommended that a State organism be created to assume the responsibility for the aspects of operation and

maintenance of the SHPS, including the continuous training of personnel or replacements when necessary. This entity may delegate administrative functions of the operation of the stations and the collecting of income from the sale of services destined to the payment of the operator and the cost of station maintenance, these duties going to the community or municipal organisms. The State entity will also regionally organize the operation of mobile units in charge of solving the maintenance problems that cannot be resolved by the SHPS operators.

The operational costs for the SHPS will be determined by the cost of the operator, in cases where the station uses manual regulation, or the cost of the supervisor, in cases where there is automatic operation, and by the costs required for preventive maintenance. In order to reduce these costs, it is proposed that the operators or supervisors be inhabitants of the locale and that standardized equipment be used so as to permit rapid repair of any mishap due to the fact that there are always replacement parts.

For the realization of the Program for the Development of SHPS, the training of ~~pro~~professionals and technicians becomes vitally important; for that end, it is proposed that specialization courses and workshops be organized and directed to the formation of professionals and specialized technicians for each stage of the development of SHPS, i.e., from the study on resources and demand to their operation and maintenance.

OLADE can fulfill a role as a dynamic orienting agent for the Program for the Development of SHPS Research and Implementation in the countries of the region. OLADE's contribution is required mainly in that referring to the elaboration of guides and manuals for carrying out the studies in the different stages, as in the cases of an orientation guide for the elaboration and evaluation of projects, a manual for the elaboration of engineering projects, and a manual for the evaluation of small-scale hydro-energy resources and the rural energy demand. Likewise, OLADE would play a fundamental role in the preparation and permanent review of the aforementioned manuals and guides, and in the technological development

and transfer of technology with respect to services and equipment.

Similarly, it is suggested that OLADE promote courses for specialization in SHPS, for professionals and technicians, contemplating curricula on non-conventional technologies for the aspects of civil construction and electromechanical equipment.

OLADE should also promote and organize courses, conferences, or workshops on subjects related to technological development, studies, operation, and maintenance of SHPS. For those, it can recur to its own professionals and technicians or to those from other organizations and institutions in the region.

3. REGIONAL PANORAMA

In the modern world, the dependence on oil together with political phenomena, the permanent increase in demand, and the larger investments required to discover new reserves, has originated a five-fold increase in the price of oil in recent years, thereby obliging the countries to revise their energy plans and to develop technologies appropriate for using new sources of energy and, especially, their hydro resources.

The slow development in many of the countries of the region, among other things, is due to the great socio-economic inequalities among the masses of population and, especially, to the disequilibrium existing between the large cities, of growing economic development, and the small, isolated locales and rural areas characterized by socio-economic backwardness. This situation has given rise to a phenomenon of migration towards population centers of greater economic activity, but thus creating serious socio-economic problems.

The geographical variety of the territory of the different Latin American countries, characterized by its abrupt orography, has favored a spatial distribution of isolated settlements, and at the same time, a large potential for disperse natural resources, especially hydro resources.

Energy, and especially electric energy, is a fundamental element for the stimulation of development for towns; however, the problems of supply and high production costs for electric energy on the basis of conventional, non-renewable sources of energy, make it imperative to recur to the use of the region's abundant hydro resources.

In accordance with the aforesaid, one of the most advantageous alternatives for covering the electric energy demand of most of the small population centers and microregions that have no possibilities of interconnecting with the existing electric systems, proves to be the generation of electricity on the basis of adjacent hydraulic resources.

In this context, the massive development of the SHPS is very important for propiating socio-economic development of isolated locales and rural areas of the countries of the region, since it would permit an improvement in the quality of life of the inhabitants by providing them with electric energy to be used in productive and domestic activities.

3.1. CURRENT SITUATION.

On the basis of general knowledge of the geographical and orographical characteristics of the countries of Latin American and the Caribbean, it can be affirmed that the potential of the hudroenergy resource for small-scale utilizarion is abundant; nevertheless, most of the countries do not have an overall estimate of the small scale resources and demands.

In the feneral terms, the development of SHPS has not been systematically put forth, except in countries such as Colombian, Panama, and Peru which have already begun planning massive construction of this type of power station and which have already arrived at the stage of works for some projects. Other countris have been developing small isolated projects, generally attempting to recolate some SHPS which were abandoned due to interconnections; and still other countries have not as yet begun any activity related to SHPS construction in the context of its rural electrification plans.

Althoug there are numerous power stations in the region which fall within the SHPS categories most of them have been built with conventional technologies and equipment imported from outside the area. Neither can it be said that these plants were conceived of as agents for rural development, all of which manifests the lack of definite policies in this regard.

In addition, the lack of an institucional organization promoting SHPS development in a planned, coherent way can also be observed.

Likewise, in many of the existing SHPS, community participation has been left aside, with the consequent limitation on their development.

3.2. PERSPECTIVES AND PROBLEMS

The development of the SHPS presents advantages from the local point of view, as well as from the national and regional ones; thus, we have:

Within the local scope:

- Improvement in the standard of living (education, health, etc.)
- Stimulus for production activities
- Creation of sources of work
- Improvement in the quality of the products (irrigation, etc.)
- Use of resources and local labor
- Deterrent to migrations

Within the national scope:

- Stimulus to rural development
- Use of renewable resources
- Substitution and savings of oil consumption
- Savings of funds
- Reduction in regional disequilibrium with the consequent economic growth
- Reduction in migration problems
- Development of national technology
- Development of technological capacity and formation of professional and technical teams
- Use of indigenous resources in the country
- Contribution to self-sufficiency and energy independence
- Creation of sources of employment, development of economic activities related to SHPS

Within the regional scope:

- Development of the region's technological capacity
- Contribution to the region's energy and technological development

For these reasons, it is recommended that a large-scale program for the development of SHPS be elaborated. However, the development of massive programs for the construction of SHPS in the countries of the region encounters a series of difficulties, which to a smaller or larger degree can be considered common; these are:

1. Lack of a definite policy with respect to rural electrification and the SHPS in particular, principally with regard to the productive use of energy.
2. Lack of a national institution in charge of advancing the development of SHPS, in a continuous, sustained way, and defining responsibilities with respect to the operation, maintenance, administration, and repair of the installations in operation.
3. High cost of the SHPS in relation to the economic capacity of the areas to be served.
4. Lack of knowledge about the magnitude of resources and the demand for SHPS.
5. Limitation of economic resources available for investment.
6. Limitations of the methods and capabilities for realizing SHPS studies, projects, and construction.
7. Limited availability of technologies permitting the massive development of SHPS with materials and technicians proper to the region.
8. Dependence on the importation of equipment.

In order to develop a massive SHPS program, it is necessary to have clear, definite objectives, an appropriate institutional or-

ganization, adequate technology, and necessary knowledge with respect to the equipment and materials produced at the national and regional levels, so that the work and projects will not generally prove to be excessively costly.

It would also be necessary to stimulate the development of national and regional technologies for the utilization of renewable energy sources; moreover, the use of mechanisms for the transfer of technology, the training of human resources, and support for national industry should also be considered.

4. PLANNING

The limitations of SHPS development, together with the recognition of the urgency of attending the necessities of electric energy in isolated locales and rural areas, make it necessary to adopt a planning strategy which permits the promotion of SHPS construction and the elimination of the limitations mentioned previously, thereby permitting the creation of the conditions for massive development of this energy source, which should be embraced within a coherent, integral plan considering the reality of the available economic and technical resources.

Thus, a model for massive SHPS development strategy is set forth in Figure No. 2, which presents a schematic framework for the matters dealt with in the present document. In subsequent figures, flow charts are shown for the different blocks in Figure No. 2.

The proposed strategy includes the execution of a series of activities directed at the elimination of the limitations to massive development of SHPS, insofar as possible, in the different countries of the region, at the same time proceeding to the execution of programs for the construction of the same. The results that are obtained should be gradually incorporated without compromising the accomplishment of the final goals that have been proposed.

Figure No. 3 shows the flow chart corresponding to the planning block from Figure No. 2.

4.1. DEVELOPMENT POLICY

A massive development program for SHPS in the region offers the possibility of developing the technological capacities through activities tending to incorporate the use of local materials and labor, with the subsequent reduction in cost and dependence, formation of personnel, and others. For this reason, it is very important to consider the development of technological research ac-

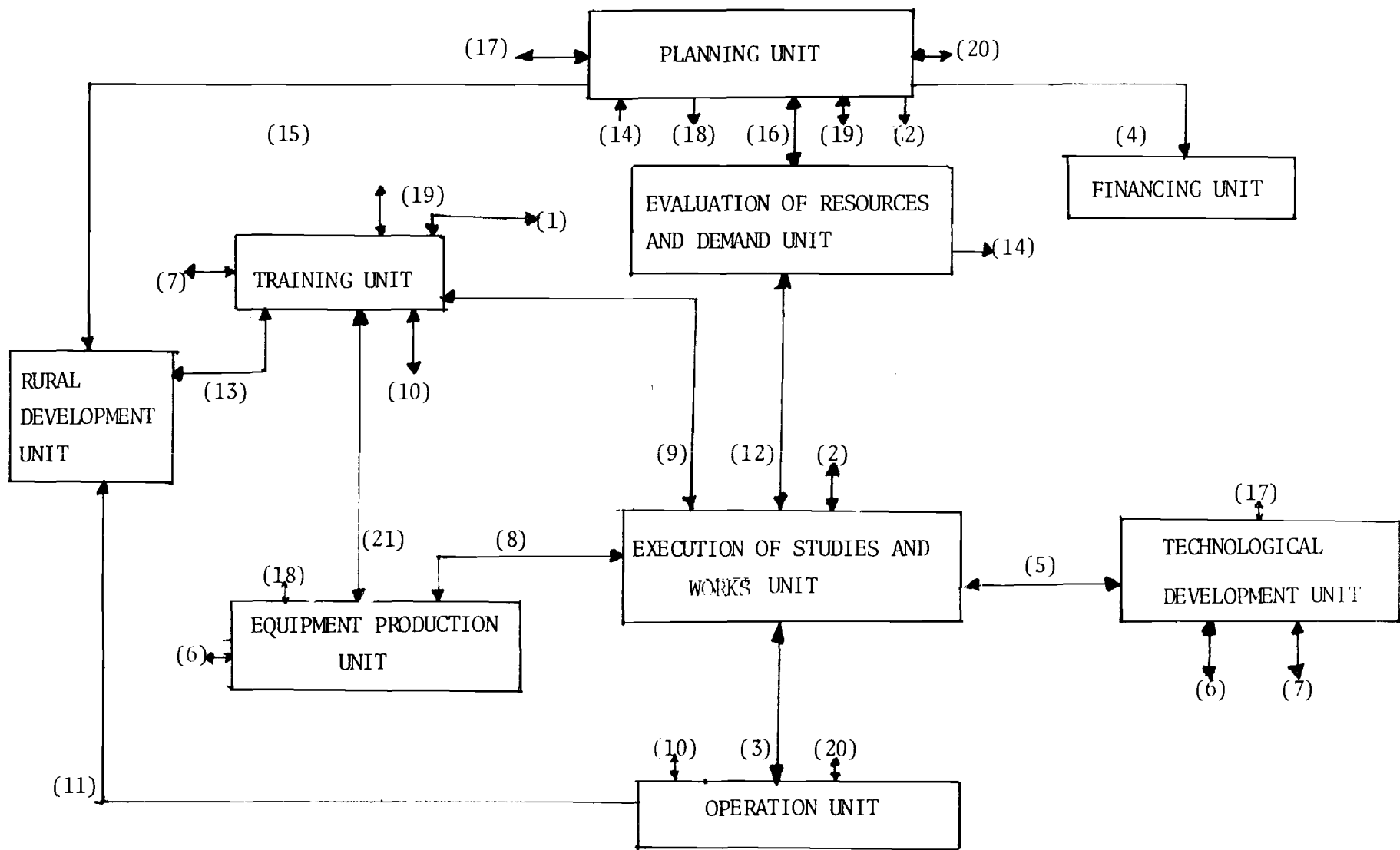

FIGURE No. 2 BASIC DIAGRAM OF RELATIONSHIPS AMONG THE ASPECTS TO BE CONSIDERED IN THE DEVELOPMENT OF SHPS

PLANNING UNIT OF SHPS DEVELOPMENT

INSTITUTIONAL ORGANIZATION OF PLANNING UNIT

FORMULATION OF STRATEGY AND POLICIES

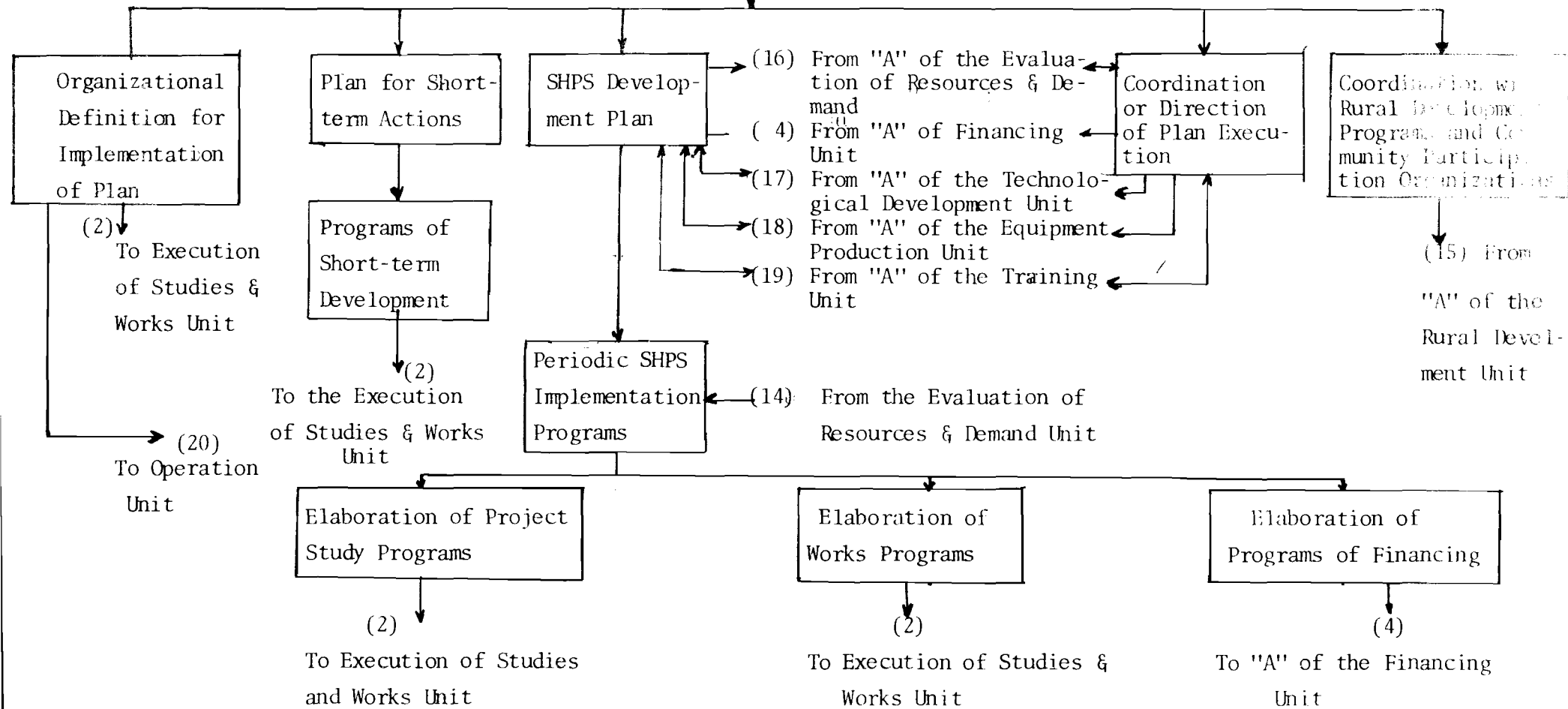

FIGURE No. 3

tivities within a program of massive SHPS development.

In addition, in the various rural communities of the countries of the region, there is an ample community tradition, which can be channeled through an adequate organization for the characteristics of each country, in order to facilitate the development of SHPS, and at the same time to reduce the cost and the need for financing.

Taking into consideration the aforesaid, the following policies for the massive development of SHPS are put forth:

- Institutional Policy

This should be within the framework of a rural development program, and specifically, within a coherent electrification program, which permits the participation of the communities, complementing the action of the institutions in charge of electric power development, in such a way as to guarantee the development of the program and its coordination with other rural development programs.

- Rural Energy Development Policy

This should be oriented to the development of productive activities which tend to increase the aggregate value of rural production, by means of the use of SHPS, in addition to attending the domestic needs of the population.

The formation of small electric systems based on SHPS should also be considered for supplying microregions and groups of localities.

- Construction Policies

It is necessary for the massive construction of SHPS to be oriented to the use of local labor and materials, to the use of technologi-

cal capacities native to the region, and the use of non-conventional construction techniques.

- Financing Policy

This should tend towards sustained execution of SHPS; thus, it is necessary to designate definite resources, on the part of the State, as well as on the part of the other institutions responsible for electrification. The participation of the communities benefitted by the financing should be fomented, as well as that of the national and international financial institutions. It is useful for this to be oriented towards consideration of project packages, with the purpose of reducing costs in the different stages of development.

- Technological Policy

This should promote technological research for the development of equipment, materials, and non-conventional techniques which possibilite a greater participation of local materials and capacities. This should tends toward the standardization of equipment and the typification of civil works. It should be situated within the context of the technological development of the Latin American region.

- Policy on Equipment and Materials

This should be oriented towards the development of the capacity for producing equipment and materials, preferentially employing technologies and inputs of regional and national origin, as well as towards the generation of conditions that facilitate the use of equipment of national and regional origin in SHPS investment projects.

- Training Policy

This should be oriented towards the formation of professional and

technical teams for the execution of studies, designs, constructions and operation with respect to SHPS, for the purpose of satisfying the need for a massive program of implementation; moreover, it should be oriented towards the training of the residents of the localities so that they may participate in the operation and administration of the SHPS. The importance of qualified local operators deserves to be pointed out. The formation of technicians for the installation of distribution networks should also be considered.

- Rates Policy

The frame of reference will be determined by the necessity of making electric energy accessible to the residents with scarce economic resources, who usually inhabit isolated localities and rural areas.

It cannot be expected that the return on the investments be a total one; however, an attempt should be made for the rates to generate sufficient resources for the financing of the operation and maintenance costs, and when possible, the partial amortization of investments and future expansion.

The rates structure should likewise favor the rational use of the electric power service and the utilization of energy in productive activities.

4.2. EVALUATION OF RESOURCES AND DEMAND

For the massive development of SHPS, it is necessary to be aware of the available hydro resources, for the purpose of formulating the construction programs and establishing an order of priorities.

The evaluation of the SHPS resources is intimately linked to the existence of a nearby demand, given that the possibility for hy-

droelectric development will, to a great extent, depend on the economic feasibility of the production and transmission of low power ranges, with tension levels below 15kW, depending on the normal tension levels in each country.

Keeping this in mind, a scheme for the evaluation of resources and demand is proposed in the general chart for the planning of SHPS development (Fig. 2); this permits the execution of SHPS programs in the degree that the evaluation of resources and demand proceeds, for a later establishment of priorities to be executed, including:

Inventory of SHPS- This consists of the identification of the existing and projected SHPS. On the basis of this inventory, initial annual programs of studies and works can be elaborated; and the needs for equipment, technological and industrial development, and training and financing programs, can be estimated. In Appendix I, the proposed form for SHPS surveys is shown, and Appendix II proposes a format for the summary sheet for the national inventory, which will serve for the elaboration of the regional inventory.

Evaluation of Resources by Basins and Watersheds.

For the purpose of having a first approximation of the available SHPS resources, their magnitude must be estimated according to the data available for each basin or watershed.

Preliminary Identification of Isolated Centers and Microregions.

The evaluation of SHPS resources is intimately linked to the need for developing such resources for satisfying the electric power demands for small localities. Likewise, the formulation of a program for the massive development of SHPS should be done on the basis of the establishment of priorities for the localities and microregions susceptible to electrification with SHPS. The preliminary identification of the isolated centers and microregions

is put forth as a group of previous activities, permitting the availability of an initial estimate of the magnitude of the problem. For the execution of this task, the form proposed in Appendix III should be completed with the information and estimates available. The following criteria are also proposed:

- To contemplate the isolated localities and rural areas which can be electrified with SHPS, up to 5000 kW, considering coefficient projections for covering electric service and realistic specific consumptions, in accordance with the characteristics of such localities.
- To make configurations of microregions, grouping isolated populations and rural areas found within the radius of the scope of the transmission lines, on the order of kW, considering the topographical characteristics of the region.

Preliminary Establishment of Priorities for Isolated Localities and Microregions that Can Be Electrified with SHPS

This consists of establishing priorities for the isolated localities and microregions identified in the previous activity, on the basis of preliminary criteria with respect to the data gathered. This activity also permits the formulation of preliminary annual programs of studies, works, financing, training, etc. The following criteria are proposed for this stage:

- Population and the existence of the hydro resource (from larger to smaller).
- Existence of conditions favorable for SHPS (topography, geomorphology, community participation, and availability of local materials resources.)
- Possibilities for regional economic development (utilization of electric energy to increase the aggregate value of the local economic production and the fomenting of other productive activities.)

- Physical interconnection with other population centers (system of roads).
- Possibility of interconnection with major systems.
- Comparison and/or combination with other energy alternatives.

Verification in the Field

This consists of verifying the data which served as the basis for the preliminary establishment of priorities; immediately, the feasibility of works construction will be verified, for which the following studies should be done:

- Verification of the isolated localities and the composition of the microregions: population estimates should be proven, as well as the possibility for electrical interconnection of the localities in order to form a small electrical system and the eventual interconnection with larger systems.
- Verification of the existence and persistence of the hydro resource, and definition of the need for more detailed measurements.
- Hydrology, geology, and geomorphology, at the global level, permitting the determination of the need for more in-depth studies.
- Topographical reconnaissance permitting decisions with respect to the possibility for, and the localization of, the site.
- Preliminary estimate of the domestic and public lighting markets, and the possibilities of increasing the consumption by small industry, irrigations, and social services. This activity should be closely coordinated with the Rural Development Programs.

Readjustment of Priorities

On the basis of the previous information, a readjustment of the priorities should be made, taking into consideration the following criteria:

- Size and cost (including the cost of networks).
- Potential stimulus to rural development (percentage of the generation destined to other productive activities).
- Community participation.
- Employment of local labor and materials.
- Capacity for supplying equipment (preferably, of national or regional origin) and available capacity of technicians and engineers.

On the basis of the priorities, the annual programs should be defined for project studies, work programs, financing programs, needs for inputs and equipment, as well as the need for technological research and industrial development, among others. This process should be understood as a continuous and repeating process which integrates the achievements made in the development of the different programs (training, technological development, etc.) as criteria for the subsequent definitions of priorities.

Figure No. 4 shows the flow chart corresponding to the block for the evaluation of resources and demand from Figure No. 2.

Appendix VII gives the terms of reference for a manual on the evaluation of small-scale hydroenergy resources and the determination of the rural energy demand in Latin America.

4.3. PLANS AND PROGRAMS: FOCUS AND METHODOLOGY

The plans and programs for the development of SHPS should be formulated taking into consideration the available financial and

EVALUATION OF RESOURCE AND DEMAND UNIT

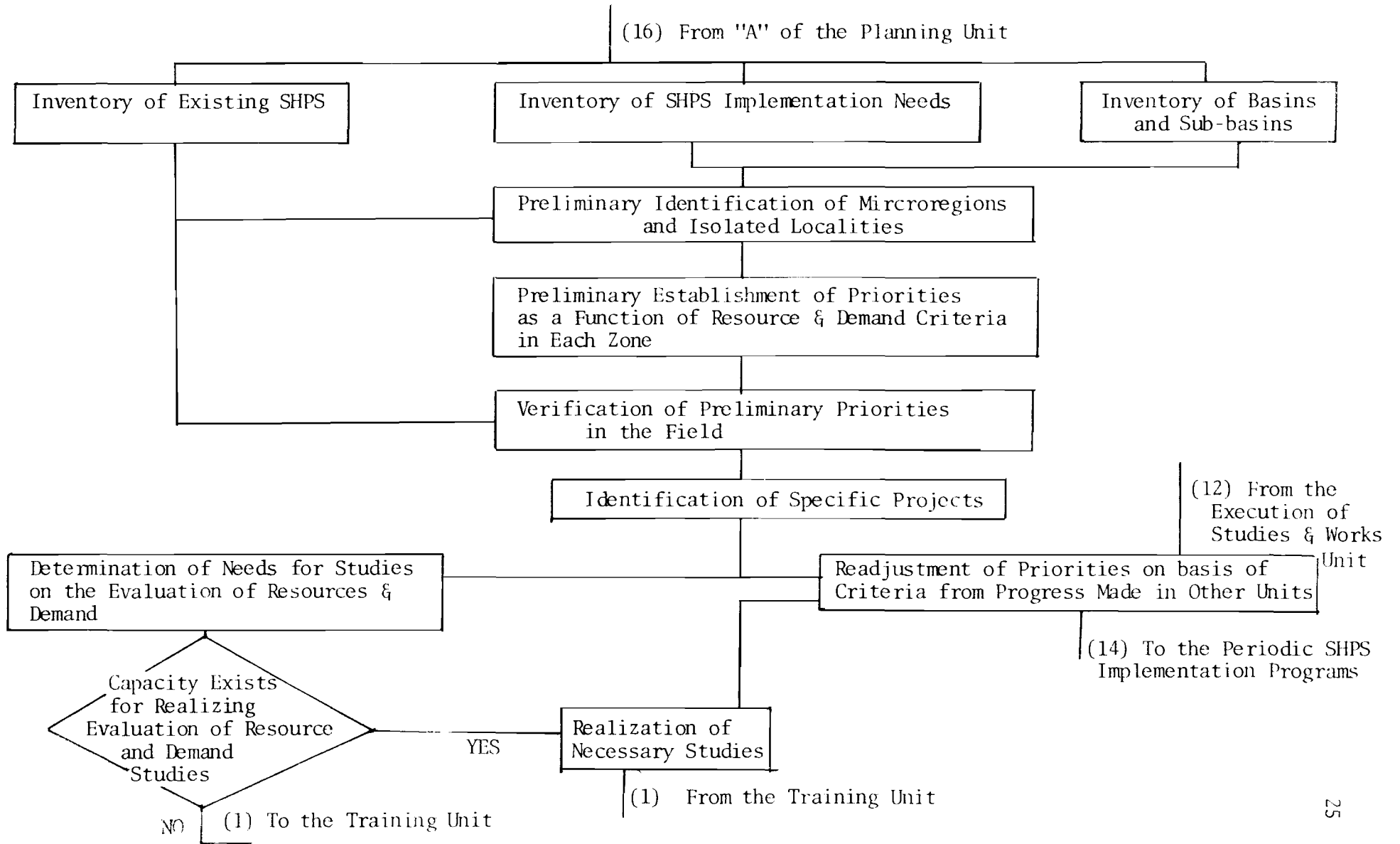

FIGURE No. 4

technical resources (investment, capacity for execution, availability of local equipment, etc.), along with the results of the different programs to be developed.

The methodologies of planning and programming should be uniform and the criteria for priorities to be adopted should be coherent with the policies proposed.

Taking into consideration that the massive construction of SHPS should be gradually implemented, , as the results of the different programs are obtained, the criteria for priorities that are put forth are given for the different stages of development of the same.

Initial Stage:

- Completion of uncompleted works
- Abandoned works (stations with advanced civil works, with equipment acquired but not installed, etc.)
- Relocalization of existing SHPS equipment
- Identified needs (new works, with studies)
- Existence of related works which could reduce the cost (irrigation, etc.).

In later stages, it is recommended that the following criteria be used, as a function of the availability of data, in accordance with the progress in other programs:

- Availability of the hydro resource
- Population to be served.
- Size and cost of the works.
- Community participation in financing; within this aspect, the valorization of the employment of local labor and the contribution of community inputs should be contemplated.
- Creation of jobs in the locality.

- Availability of access roads and systems of roads connecting with other urban centers.
- Use of the electrical energy generated in productive activities; increase in the aggregate value of production.

On the basis of the priorities, the following annual programs should be defined, taking into consideration the availability of economic resources, professional and technical resources, and those of materials and equipment:

- Studies: The studies to be done each year, their content and level, will be indicated, in accordance with the preliminary knowledge available.
- Works: The annual construction programs, the need for materials, equipment, professionals, labor, etc., will be specified.
- Financing.

Likewise, the need for equipment, labor, professional and technical personnel, and financing should be defined, on the basis of which plans and programs for technological development, equipment construction and training will be formulated.

4.4. ASPECTS OF INSTITUTIONAL ORGANIZATION

It is considered useful for the countries to have a governmental entity in charge of promoting and coordinating the implementation of SHPS. This entity could depend on an electric power company or another State institution, but it should be emphasized that it is necessary for it to be dedicated exclusively to the development of this energy source and for the personnel composing it to have qualifications so as to guarantee that the original concept of the project not be lost.

Among the duties that this entity should cover, we have:

- Registering information.
- Catalog of localities without electrification.
- Catalog of hydraulic resources.
- Orientation of particular applications.
- Information brochures.
- Coordination of personnel capacity.
- Coordination of community action.
- Financial orientation and applications.
- Negotiations for equipment acquisition.
- Definition of rates for each center.
- Formation of electrification committees.
- Identification of need for technological development, proposal of actions to research institutes, and evaluation of the application of technologies.

For the activities from the planning to the construction of SHPS, the institution in charge should take the following actions:

1. To determine which isolated centers or microregions can be serviced by SHPS.
2. To establish an order of priorities for the centers and microregions and their overall necessities.
3. To prepare or delegate the elaboration of studies and engineering designs for the stations to be installed in the said centers and microregions.
4. To define the financial sources.
5. To define the form in which the construction is to be carried out and organized; if it is relative, to form contracts or to execute the work by administration, forming an electrification committee from the community in charge, in order to facilitate labor, materials for aggregates, and in general, to coordinate the support of the community.
6. To serve as counterpart for equipment acquisition.

7. To organize the future operation and maintenance.

The institution would also be in charge of coordinating international technical cooperation to facilitate technologies and methodologies already developed in other countries of the region and to complement the national efforts; and finally, to fulfill the original objective of the program, an attempt should be made at giving continuity to the construction of power stations, to training, and to motivating the communities to adopt this kind of energy solution.

The SHPS program can fully comply with its principal objective of stimulating the economic and social development of the depressed populations if it can count on the ample and sustained support of the areas to be benefitted, for which reason it is necessary to organize the populations in such a way as to channel their participation through a pro-electrification committee composed of authorities and responsible representatives of the site.

5. STUDIES AND FINANCING.

5.1. REQUIREMENTS AND SCOPES OF THE SPECIFIC PROJECT STUDIES.

From the point of view of the organization of the studies, there is a need for a project identification stage, which should be related to the previous planning and programming activities. This stage can be applied in the 3 kinds of SHPS considered herein.

The objective of this stage would result in a second selection of sites with technical and economic possibilities; the first selection would have been made during the last stages of planning. The degree of detail in some cases would include economic prefeasibility by means of an indirect analysis of the rates possibilities. With regard to the land sciences, cartography and topography should be considered rapid inspections which at the same time permit the selection of the best projects from the start. This would imply an analysis at the levels of basins and subbasins.

The projects which present doubtful situations with respect to follow-up decisions to the studies should be subject to a feasibility study. In most SHPS projects, detailed geotechnical studies do not seem to be necessary; a planned program of surface exploration would be sufficient. Likewise, for the hydrotechnical studies, a degree of depth must be considered in relation to the magnitude of the investments. This consideration proves valid for the geological, geomorphological, and geotechnical studies. Given that the SHPS civil works are of a reduced size, the ecological impact produced in the watershed is minimal; in the case of ecology, inspections before and after the definition of the project and a plan for managing the basin would be sufficient.

The schemes or pre-designs should permit a quantitative and comparative feasibility analysis in economic terms, in relation to other alternatives from other sources to satisfy the demand.

For the construction blueprints or the design stage, it is necessary for these to permit a sufficient orientation for the activity of implementing the work. This implies the perfecting of schemes or hydraulic pre-designs, the necessary geotechnical complements, the structural calculations, the determination of the amount of work, and the elaboration of a budget and a chronogram for the execution of the work, permitting the initiation of the building process.

In the identification stage, with respect to the selection of electromechanical equipment, it would be sufficient to mention the most appropriate kinds. For the feasibility stage, it is necessary to verify a first optimization of equipment. It is useful to examine the costs, according to the manufacturers' charges, for the various equipment alternatives. In general, it is useful to keep in mind that in most cases, the projectors do not design the equipment; this activity is done by the manufacturer.

The objective of the studies finally consists of the determination of the demand and its variation with time, the available falls, and the variation in flows and their relationship with demand.

It is useful to consider the realization of programs in packages, in view of the high cost of the individual SHPS projects. This would facilitate the procuring of financing, the control of the execution, the obtaining of better conditions with respect to the acquisition of equipment, materials and facilities for contracting studies and construction. Figure No. 5 shows the flow chart corresponding to the financing unit from Figure No. 2.

FINANCING UNIT

FIGURE No. 5

5.2. REQUIREMENTS FOR INVESTMENT AND FINANCING

The needs for the field of electrification in rural and isolated areas are very large in Latin America (with barely 15% covered) and they greatly exceed the availability of the economic and financial resources that the region can dedicate to this end. From the aforesaid, we have the need for establishing selection criteria which permit attending the necessities of as many users in these areas as possible, in each stage of the execution of programs.

In Number 4, the selection criteria were considered in more detail, for the purpose of establishing priorities, of which it seems useful to point out the lower cost per user and the prospects of promoting the productive utilization of electric energy.

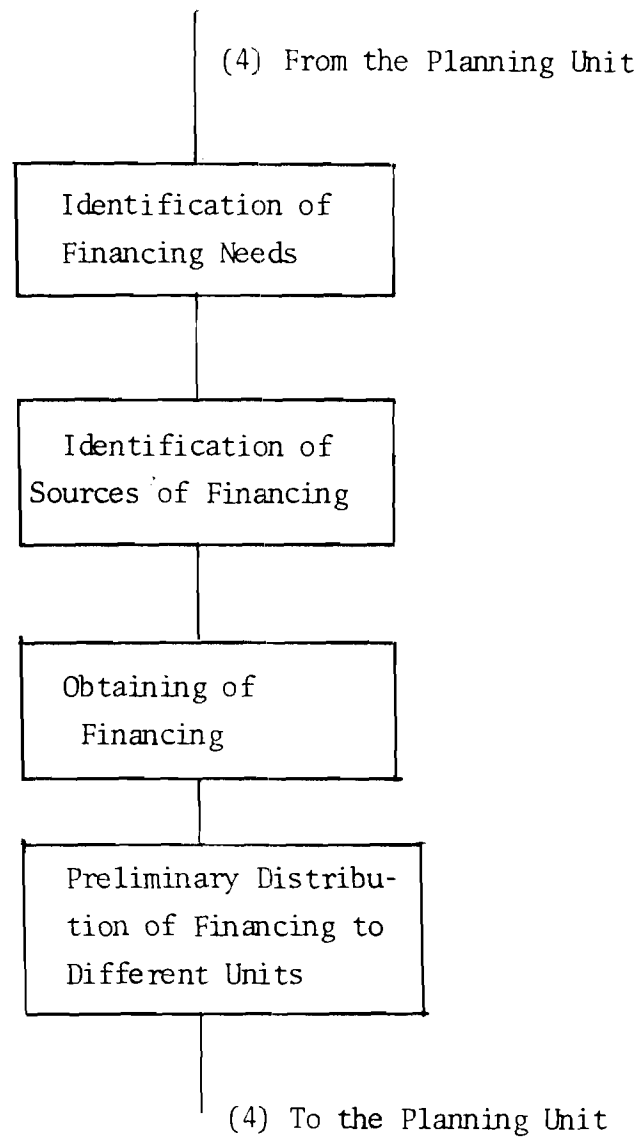
Given that in relation to the selection criteria it is also considered important to contemplate the projects with respect to the total productive process, it is useful to do a study providing a tool for economic and financial analysis which does not exclusively consider the economic feasibility.

To consider the total productive process implies a focus on the projects in light of the rural and integral development plans, which include the productive sector as well as the social sector. In summary, the projects should be linked to the total socio-economic context.

With the exception of the producers for self-use, the SHPS projects will, for the most part, serve communities having a reduced economic capacity and, consequently, these are not in a condition to finance all of the investment. In these circumstances, considerable support is required from the national budget. For the purpose of assuring the extension of the SHPS benefits, i.e., their massive diffusion, it is thought useful to contemplate guides for the optimal

use of the energy within these programs, with special emphasis on the productive use of the same. Community participation holds special importance for reducing the contribution of the users in cash. The valorization of such participation should be estimated on the basis of real labor costs, for the purpose of avoiding distorted focuses in the evaluation of projects.

With the aim of reducing the component of currency in the programs, massive participation should be fomented among the national engineers, for studies as well as for construction; in the same way, it is considered important to develop the capacity for supplying equipment and materials, at the levels of the countries and of the region.

The desirable goal with respect to the cost per kilowatt installed is considered to range between U.S.\$1000 and \$2000, at 1980 costs.

With regard to the actions and methods for reducing investments in SHPS, it is thought useful to initiate regional research activities and to organize the elaboration of design and feasibility manuals and guides for the terms of reference, which permit adapting the studies on costs and construction to the capacities to be installed in the projects. In other words, the previous research permits a sufficient degree of normalization which leads to a reduction in the costs of engineering and equipment.

OLADE will play a fundamental role in promotion, coordination, and advising, not only in the preparation and permanent revision of the aforementioned manuals and guides, but also in the aspects of the transfer of technology with respect to services and equipment.

It would be extremely important to create funds for financing the development of electrification in rural and isolated areas on the basis of the development of SHPS, with respect to studies as well as to the construction of works.

It is useful for OLADE to prepare guides and manuals for the elaboration of studies in their different stages. Appendix V presents the terms of reference for an Orientation Guide for the Elaboration and Evaluation of SHPS Projects. Appendix VI is composed of a proposal of the terms of reference for a Manual for the Elaboration of SHPS Engineering Projects in Latin America. Appendix VI considers the terms of reference for a Manual for the Evaluation of Small-scale Hydroenergy Resources and Rural Energy Demand in Latin America.

5.3. TECHNOLOGICAL CONSIDERATIONS.

An outstanding aspect of this point would be a discussion of the possible application of technologies adapted to the characteristics proper to the countries of the region, and non-conventional technologies, in the projects; the latter may be appropriate for the development objectives of the country and for the regional or local socio-economic conditions. The discussion should emphasize the greater utilization of these technologies and the way in which they could facilitate the creation of productive jobs and larger incomes, in the rural areas as well as in the isolated areas. The construction and design technologies currently being used in the region of the project should also be studied, along with the impact that various mixtures of technologies have had on employment and production goals, the scope of the variations and substitutions, and their effect on governmental policy.

In view of the fact that there is production of SHPS equipment and materials in the region, it becomes very important to diffuse the results of the information surveys on technological research and equipment, periodically, as indicated in the document "Situation and Prospects for the Technology and Equipment for Small Hydro Power Stations in Latin America." This will contribute to a reduction in investment costs for the SHPS projects. The task which OLADE must take on in these aspects is of great importance in relation to its role as the promoting and coordinating agent for this and other

energy matters. Figures Nos. 6 and 7 show the flow charts corresponding to the blocks of technological development and equipment production from Figure No. 2.

TECHNOLOGICAL DEVELOPMENT UNIT

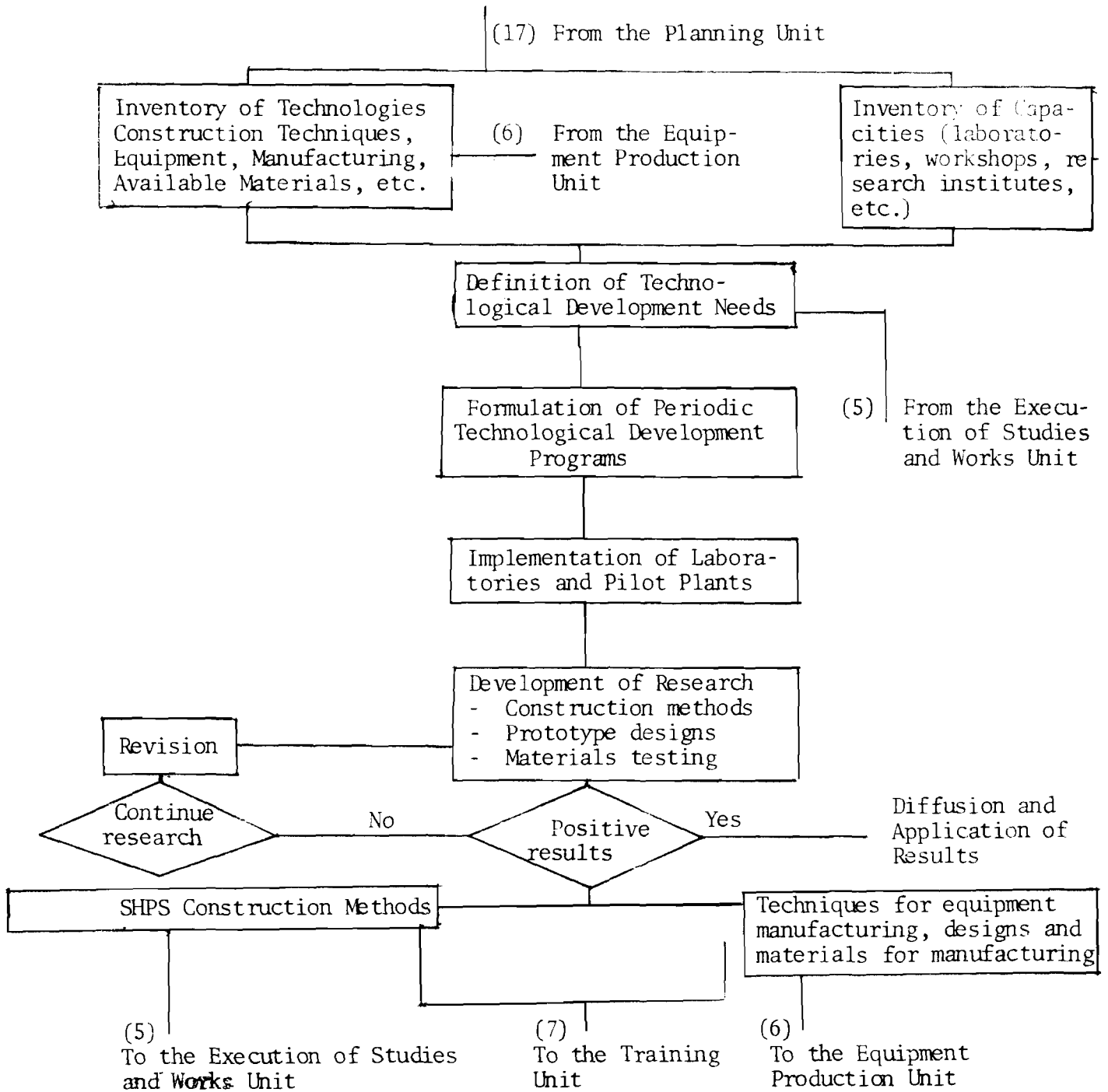

FIGURE No. 6

EQUIPMENT PRODUCTION UNIT

From the Training Unit
(21)

From the Execution
of Works Unit (8)

From "A" of the
Planning Unit (18)

From the Techno-
logical Develop-
ment Unit (6)

Inventory of Available
Production Capacities and
Technical Materials

Inventory of Equipment Pro-
duction Needs

Natio-
nal Equip-
ment Production
Exists

Yes

(8) To the Execution
of Works Unit

Fomenting of Pro-
duction: coordina-
tion with manufac-
turers

Yes

Natio-
nal Tech-
nology is
Available

Yes

Pro-
duction
Capacity Exists

No

Importation of
Equipment

(8)

To the Execution
of Studies and
Works Unit

From the Technological
Development Unit
(6)

Production of
Equipment and
Materials

No

Capa-
city for
T.D. Exists

Yes

(6) To the Techno-
logical Develop-
ment Unit

To the Execution of
Studies and Works
Unit

Adquisition of
Technology

(21) To the Training Unit

FIGURE No. 7

6. CONSTRUCTION.

The construction processes will vary in accordance with:

- Power range to be installed.
- Characteristics of the terrain.
- Location of the work.
- Utilization of the work.
- Isolated or interconnected utilization of the power station.
- Availability and level of qualifications of labor.
- Construction technology.
- Facility for access and transportation.
- Technological level of equipment.
- Climatic conditions.
- Effects on multipurpose projects.

All of the aforementioned factors influence the work, as analyzed below.

6.1. METHODS, EQUIPMENT, AND INSTALLATION.

The SHPS require characteristics oriented to minimizing costs and to utilizing the local human and material resources, for which reason the construction methods, equipment, and installations are different than for larger undertakings. Considering the aforesaid, the following modes of construction and equipment are suggested:

- Community construction with minimal technical assistance.
- Total or partial State construction, according to community participation
- Total or partial private construction, in accordance with State support with respect to machinery and equipment in removed areas.

It is recommended to use local labor and materials almost exclusively in the case of micro-stations, for the construction of

small dams on flat areas or intakes at the edge of the water in mountainous terrain. For mini- and small stations, it becomes necessary to use a minimum of construction and transportation machinery and equipment, in addition to a larger use of industrial-type construction materials.

For small power stations, it may be necessary to build an electric sub-station to feed the local distribution, depending on the distance from the site of energy consumption.

In micro- and mini- stations, the electro-mechanical system should be compact and reliable, within what is feasible in terms of economy and efficiency, so as to have the simplest assembly and maintenance.

6.2. CAPACITY FOR EXECUTION AND COMMUNITY PARTICIPATION

The construction of the station can be a charge of the State institutions, with or without private advising; of the private organizations, or of community action with advising. In the case of the State, the capacity of the human and material resources should be analyzed, given that their magnitude must be sufficient to guarantee the execution of the project; in the case of the private organizations, a directory of companies must be available, including their qualifications for execution, depending on their experience, capital, equipment, and technical level.

In the case of State construction, community participation constitutes an important factor because of its labor contribution. The experiences of community participation in each country become an important factor in determining its weight within SHPS construction. In this case, the formation of Electrification Committees in the communities contributes to a better organization of local support. Figures Nos. 8 and 9 show the flow charts corresponding to the blocks for the Execution of Studies and Works and Rural Development (Promotion of Rural Development and Community Participation).

EXECUTION OF STUDIES AND WORKS UNIT

(2) From the Planning Unit

INVENTORY OF CAPACITIES FOR EXECUTION OF STUDIES AND WORKS

(3) From the Equipment Production Unit

Determination of Needs for Execution of Studies

Determination of Needs for Execution of Works

Determination of Equipment and Materials Necessities

Capacity for Execution of Projects Studies

Capacity for Execution of Works

New Technologies Needed

Availability of Equipment and Materials

Elaboration of Studies

Execution of Works

Feasible Project

From the Training U.

To the Training Unit

(5) To the Technological Development Unit

(5) From the Technological Development Unit

No

(12) To the Evaluation of Resources and Demand Unit

(3) To the operation Unit

(8) To the Equipment Production Unit

RURAL DEVELOPMENT UNIT

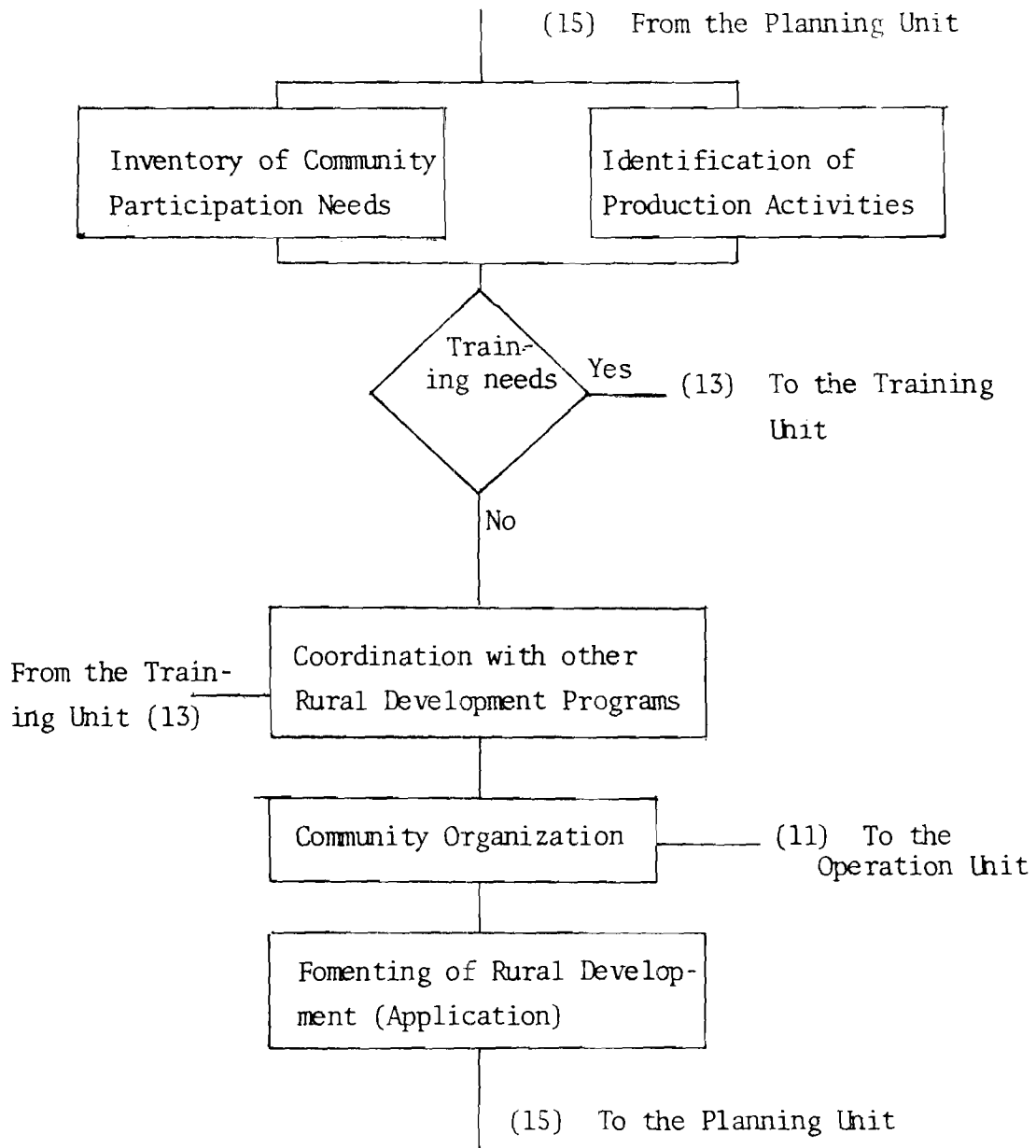

FIGURE No. 9

7. OPERATION AND MAINTENANCE.

The operation and maintenance of SHPS can assume different forms, depending on the location, kind of control, and the institutional system of each country.

7.1. INSTITUTIONAL ASPECTS AND RATES.

The beginning of a large-scale plan for the development of SHPS in the countries of the region makes it necessary to dedicate much attention to the institutional form to be adopted in order to assure a reliable and continuous operation of the power stations; and, according to each case, it clearly specifies the obligations corresponding to the communities or municipalities.

It is recommended that an Entity be created- or reinforced if one already exists- within the State structure, to assume the responsibility for the operational aspects of the SHPS in operation, including personnel training.

The community or municipality organisms could carry out the administrative functions related to the operation of the power stations and could act as the collectors of the income produced from the sale of the services, to pay the salaries of the local operator and to maintain reserve funds for maintenance. The technical aspects which cannot be resolved at the power stations would be taken care of by mobile units regionally organized by the State Entity.

The State Entity should have adequate financial resources to permit its acting to resolve emergency problems, mechanical failures and mishaps in the power station.

It is useful for the outside maintenance supplies to be planned and for their acquisition to be centralized through the State En-

tity; therein lies the advantage of standardization. In certain cases, small national or area workshops are justified for making repairs that cannot be made in the power stations, due to inadequate conditions.

7.2. METHODS OF OPERATION AND OPERATORS.

The specialized State Entity will be responsible for the operation of the power station, but it can use the local authorities and the community systems for this aspect.

The operation may be manual, with the aim of avoiding the use of **high-cost** speed regulators which in very small units can have the same value as the turbine; this scheme may be useful when the operation of the power plant does not present large load variations. Alternatively, having a reliable speed regulator has some principal advantages: lower requirements for the operator's qualifications, greater equipment safety, and better service quality.

The operator of the power station should be an inhabitant of the same community, duly trained, and preferably, a participant from the time of the construction and assembly of the SHPS.

7.3. UTILIZATION OF THE ELECTRIC ENERGY.

The use of energy for different activities will be limited by the volume generated and by the efficiency of the appliances used by the consumers. The energy consumption structure is discussed below:

- According to the size of the power station, one or several sectors could be covered. Within the residential sector, the energy will primarily be used for lighting, and additionally, for household appliances, while always seeking the most efficient ones.

Good local organization with respect to the use of the energy will permit keeping the power station operating at its full capacity and satisfying greater needs, such as health, water pumping, industrial workshops, commercial refrigeration, and others. Better utilization of the installed capacity can be achieved by promoting productive activities which demand electric energy, principally during the day-time hours, thereby demanding effective coordination for its utilization.

The Entity should have a simple structure, but a very effective one, with the indispensable technical and administrative teams.

The electric power service should be assessed in accordance with the system of electricity rates to be established, depending on the capacity generated by the power station. Among the different variations on the application of rates, the so-called consumption and fixed price ones predominate, the latter being more advisable in the case of the micro-stations, where the consumption is controlled by means of adequate limiting factors. In the mini- and small power stations, although the aforementioned rate is applicable, a differential rate can be adopted for commercial and industrial consumers, with their consumption being controlled by means of meters.

The total income obtained through the application of the rates should cover at least the operation and maintenance expenditures, for the purpose of avoiding the deterioration of the system.

7.4. MAINTENANCE AND REPAIR.

For the maintenance, it is recommended that a mobile unit be organized, dedicated to this activity and including the repair of mishaps, since due to reasons of cost and the limitations of qualified personnel, it is not justifiable to have a technical team for each one of the SHPS. It is useful for the operator to

receive training in order to realize preventive maintenance work.

It becomes necessary for each plant to have a small workshop with a minimum of tools and equipment which permit the operator to do minor repairs and which serve as support for the mobile unit, to be composed of two medium-level technicians, specialized in the field.

Each power station should have a copy of the blueprints, for the civil structures and for the electro-mechanical system, in order to facilitate the maintenance of equipment and installations.

It is important to seek permanency in the operator and to facilitate his continued attention to the station, for which it is recommended that the housing be annexed to the power station and conceived as part of the project.

In addition to his functions at the power station, the operator could realize technical activities for community service.

7.5. USE OF THE WATER.

The use of the water is subject to each country's legislation and the priority which must be given to water supply, irrigation, or the generation of energy.

It becomes necessary to make an agreement among the institutions which, in one way or another, participate in the utilization of the water, in order to determine the priorities and to establish the rules for exploiting this resource. The legislation with respect to the use of the water should contemplate better conditions for overcoming conflicts with regard to its use and for differentiating the criteria for the authorization of its use, depending on the magnitude of the project, for the purpose of not hindering the study or the execution because of administrative processing, which is usually slow.

7.6. OPERATION COSTS.

The operation costs will be affected according to the kind of operation which the plant has; if the operation is automatic, the costs will be limited to the supervision scheduled; and if it is manual, the principal element of the cost will be the labor represented by the operators, whose number will vary according to the daily generating time and the size of the power station.

There are costs which all kinds of SHPS have in common, such as those originating in lubricants, electrical material, and mechanical parts, all necessary in the operation and all requiring appropriate reserves in each station and at the centralized level. It is necessary to point out that the dependence on imported parts for equipment occasions higher costs or interruptions in service which are reflected in the per unit generating cost.

The origin of the operator greatly influences his permanency and his salary; therefore, it is recommended that no outside operators be brought in, but rather that the local inhabitants be given proper training.

The operation costs can be significantly reduced by the standardization of equipment, since this permits efficient and rapid repair of any mishap, due to the fact that there are always replacement parts and lower stocks can be maintained.

Figure No. 6 gives the flow chart corresponding to the block for Operation from Figure No. 2.

OPERATION UNIT

FIGURE No. 10

8. TRAINING.

8.1. ENGINEERS AND TECHNICIANS.

It is suggested that OLADE promote specialization courses on SHPS, contemplating a curriculum for non-conventional technologies, for the aspects of civil construction, as well as for electro-mechanical equipment. This suggestion embraces the field of formation of engineers and medium-level technicians.

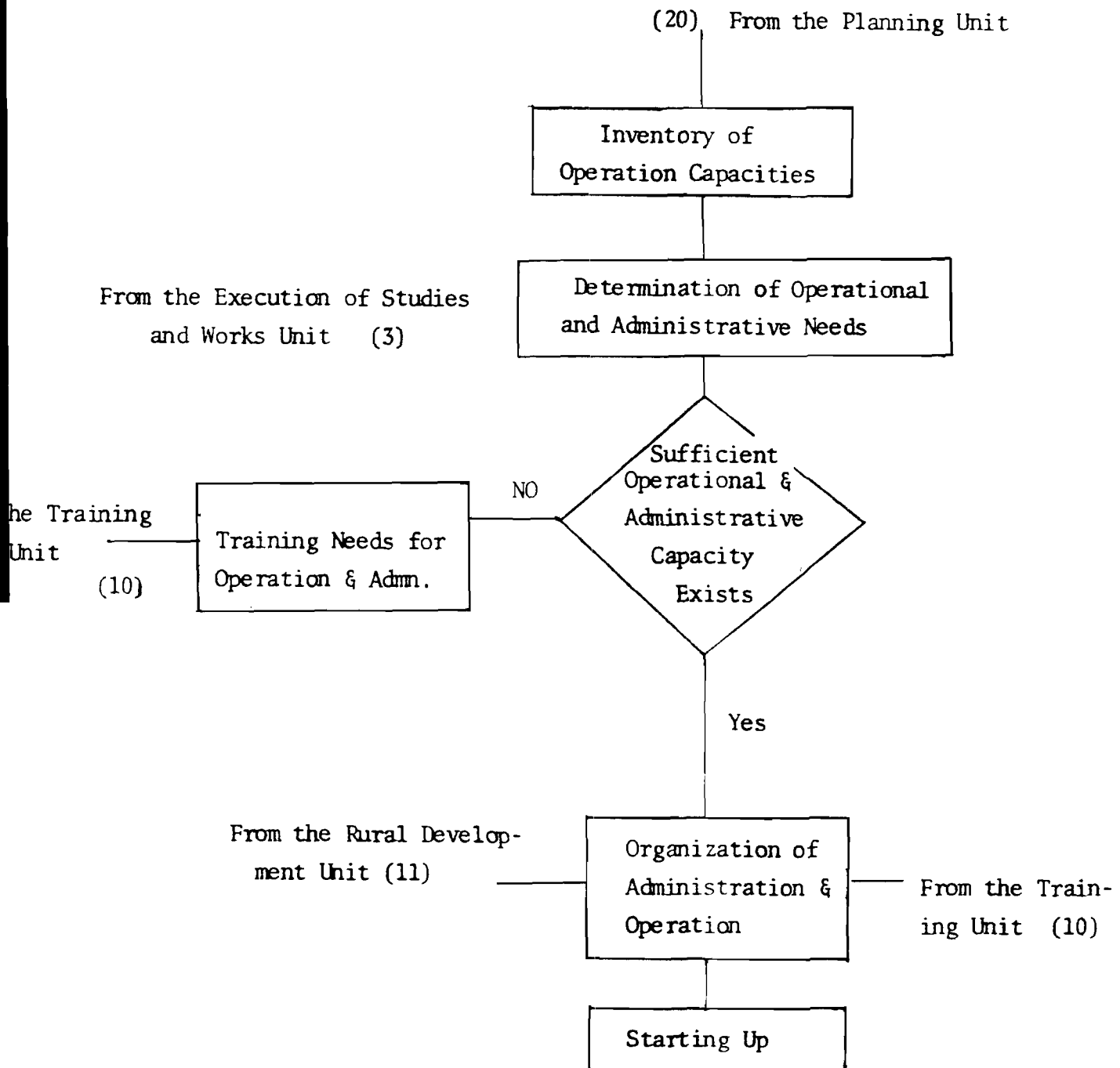
At the same time, OLADE could coordinate the inclusion of subjects which consider the non-conventional alternatives within the normal curriculum of the different engineering schools and programs for the formation of medium-level technicians. In order to avoid a duplication of effort, it would be necessary to determine the characteristics of the regional infrastructure and to take reinforcing actions for the centers most advanced in this subject.

In the beginning, a specialization program should be tried out, considering the general aspects of the hydro resources in the rural area or isolated zones, in order to detect the convenience of offering even greater specialization at a later time, with respect to the massive development of SHPS.

It would be of great importance to create financial funds for the development of the aforementioned specialization courses.

Appendix IX proposes bases for the SHPS Specialization Courses for Engineers and Medium-Level Technicians. Their implementation is proposed at the regional level.

3.2. PERSONNEL FOR CONSTRUCTION, OPERATION, AND MAINTENANCE.

The degree of the construction personnel's qualifications will be a function of the dimension of the work; however, there is a notorious lack of personnel with basic knowledge about SHPS construction. This implies the necessity of creating centers or of dictating isolated regional courses for training personnel.

The adequate organization of the local Electrification Committees, in order to assure effective support of the SHPS on the part of the population, requires the training of its members so as to obtain basic, realistic data, to facilitate the elaboration of studies and projects.

The requirements for unqualified personnel not generally a problem in the region, given that labor is abundant in most of the places where SHPS construction is programmed. The harvests, etc., which give rise to a great demand for labor, must be kept in mind, or else these can occasion problems with respect to costs or the availability of personnel for the execution of the works.

Personnel, preferably from the site, should be trained for:

- a) Collaborating on the studies and projects.
- b) Collaborating on the execution of works and installations (mechanical and electrical).
- c) Operation and maintenance of the Power Stations and Electrical Networks.
- d) Administration of the Electric Services.

Each country should create training schools for operators and the technical personnel in charge of the SHPS maintenance, to be organized by the State.

In this regard, the creation of training schools is required as follows:

- Pro-electrification Committee
- Personnel training for the installation of the transmission and distribution systems, and the house and industrial connections.
- Personnel training for the operation and maintenance of the power stations and electrical networks.
- Personnel training for the administration of small electric systems.
- Personnel training for instruction of the populations on the applications and use of the electric energy.

The channeling of information, experience, technicians and engineers on the part of OLADE will be a great support for the Member States, given that it is feasible to create advising groups which permit the extension of knowledge about SHPS operation and maintenance and the sharing of particular experiences through courses, conferences, or seminar-workshops.

It is useful to consider the creation of a Field School in each country, for the theoretical-practical training of personnel in operation and maintenance. Likewise, the pilot plants where non-conventional technologies are being experimented with should serve as instruments for training in such technologies.

The training of engineers and technicians for the maintenance, repair, and reconstruction of equipment can be done in training units annexed to the principal workshops.

These aspects of training in the SHPS work have already been implemented in some of the region's countries, and OLADE needs to promote the exchange of experiences, information, and the organization of courses at the regional level, oriented to the formation of instructors.

Appendix X proposes guidelines for the operator training courses. Figure 11 shows the flow chart for 'Training' from Figure No. 2.

TRAINING UNIT

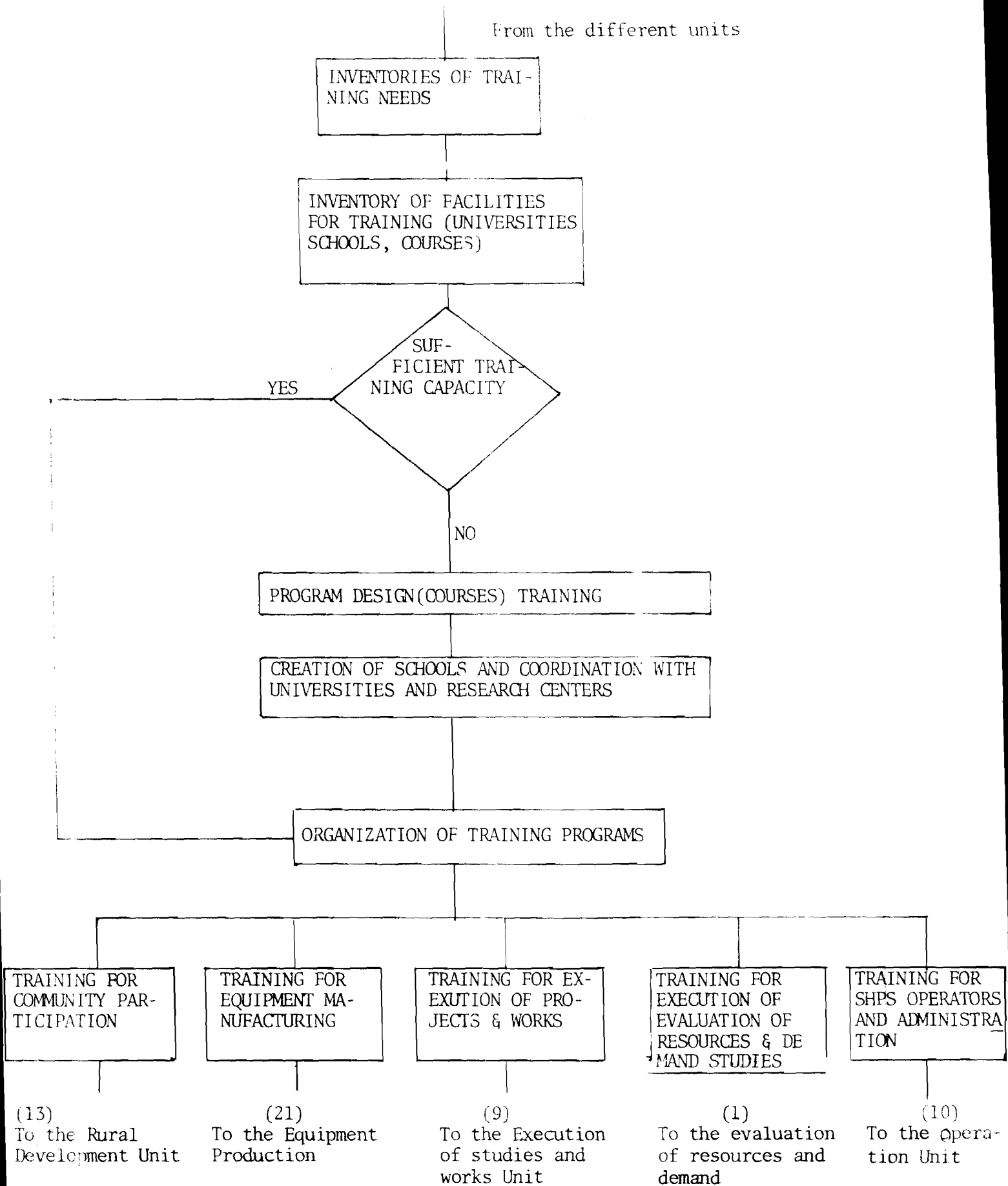

Fig. No. 11

APPENDIX I

FORM FOR SHPS DATA SHEET

Name of the SHPS:

Location:

(1)	(1)	(1)	Location

(1) Define according to political-administrative division of the country.

BASIN	SUB-BASIN		WATERSHED	
Capacity	Area (km ²)	Minimum Daily Flow (m ³ /sec)	Maximum Flood Flow (m ³ /sec)	Multi-year Average Flow (m ³ /sec)

(2) Alternatively indicating basin or sub-basin data.

Status of the SHPS: Existing <input type="checkbox"/> Under construction <input type="checkbox"/> Projected <input type="checkbox"/> Condition of the SHPS: Good <input type="checkbox"/> Bad <input type="checkbox"/> Inoperative <input type="checkbox"/> Status of the Networks: Existing <input type="checkbox"/> Under construction <input type="checkbox"/> Projected <input type="checkbox"/> Condition of the Networks: Good <input type="checkbox"/> Bad <input type="checkbox"/> Inoperative <input type="checkbox"/> Power installed or to be installed (kW) (5): Maximum Demand Foreseen (kW): Annual Energy Mean (kWh): Kind of Turbine: Design Flow (m ³ /sec): Gross head (m) (4):

(3) In generator terminals

(4) Difference between upper level of water in the forebay and the lower level of head utilization in the turbine.

Population Served:
Number of Consumers:
Use of electric energy (%)
Public Lighting Household Commercial Industrial Irrigation Mining Others
Others (Explain.):

Productive activities using electric energy (Detailed: carpentry, bakery, brick-making, etc.)

OBSERVATIONS:

APPENDIX II

FORM FOR SUMMARY SHEET ON NATIONAL SHPS INVENTORIES

Country:

Hydro Power Potential (1)	Power (kW)	Energy (kWh)
Total: Studied		
Estimated		
For SHPS: Studied		
Estimated		

(1) Technically and economically utilizable

Installed SHPS:

Number:	Power (kW):	Energy (kWh):	
Status: Good	Bad	Inoperative	
Ranges and kind of turbine	Low fall (Axial)	Medium fall (Francis or Mitchell)	High fall (Pelton)
Up to 50 kW			
51-500 kW			
501-5000 kW			

SHPS: Projected or under construction

Number:	Power (kW):	Energy (kWh):	
Ranges and kind of turbine	Low fall (Axial)	Medium fall (Francis or Mitchell)	High fall (Pelton)
Up to 50 kW			
51-500 kW			
501-5000 kW			

SHPS: Estimated Installations

Number:	Power (kW)		Energy (kWh)	
Ranges and kind of turbine	Low fall (Axial)	Medium fall (Francis or Mitchell)	High fall (Pelton)	
Up to 50 kW				
51-500 kW				
501-5000 kW				

APPENDIX III

FORM FOR DATA FOR THE IDENTIFICATION OF ISOLATED CENTERS AND MICROREGIONS

Name of Population Center: _____

Location Data:

(1)	(1)	(1)

(1) According to the political-administrative division of the country.

DEMAND

Population		Pop. Density (inhab/km ²)	
No. of abandoned potentials			
Domestic	Commercial	Industrial	Others

WATERSHED TO WHICH IT BELONGS

AREA (km ²)	MINIMUM DAILY FLOW (m ³ /sec)	MAXIMUM FLOOD FLOW (m ³ /sec)	ANNUAL OR MULTI-YEAR AVERAGE FLOW (m ³ /sec)

SPECIFICATION ALTERNATIVES

	Alternative 1	Alternative 2	Alternative 3	Alternative 4
FALL UTILIZABLE FOR SHPS (m) (2)				
FLOW UTILIZABLE FOR SHPS (m ³ /sec)				
INSTALLABLE POWER FOR SHPS (kW)				

- (2) Measured from the intake level up to the minimum utilizable level in the discharge.

STATUS OF SERVICE

Available electric service: Yes <input type="checkbox"/>	No <input type="checkbox"/>	
Kind: Hydraulic <input type="checkbox"/>	Thermal <input type="checkbox"/>	Transmission from larger E.S. <input type="checkbox"/>
Quality of Service: Good <input type="checkbox"/>	Bad <input type="checkbox"/>	Fair <input type="checkbox"/>
Year of installation or interconnection:		
Level of sub-transmission tension (kW):		
Condition of Networks: Good <input type="checkbox"/>	Bad <input type="checkbox"/>	Fair <input type="checkbox"/>

Hydraulic Generation: Existing <input type="checkbox"/>	Under construction <input type="checkbox"/>	Projected <input type="checkbox"/>
Condition of SHPS: Good <input type="checkbox"/>	Bad <input type="checkbox"/>	Inoperative <input type="checkbox"/>
Installed Power (kW):	Max. Demand:	Energy (kW):
Available head (m):		
Utilizable flow (m ³ /sec):		
Distance from SHPS to population center (km.):		

Note: In case several units exist, indicate the characteristics of each.

Thermal Generation: Existing Under construction Projected
 Condition: Good Bad Inoperative
 Installed Power (kW): _____ Maximum Demand(kW): _____ Energy(kW): _____
 No. of Groups: _____ Potential of each: _____ Kind of equip.: _____
 Fuel Used: _____ Efficiency(kWh/gal.): _____

Generation from other Elec. System:
 Existing Under construction Projected
 Line capacity(kW): _____ Length(km): _____
 Power of Largest E.S.(kW): _____ Total annual Energy(kWh): _____
 Maximum Demand (kW): _____
 Type: Hydraulic
 Thermal Fuel Used
 Mixed

ROADS SYSTEM

Road: Asphalted Paved Unpaved
 Transitability (mos./yr.): _____

Distance from other population centers:	Center	Distance(km)

IRRIGATION

Number:	Existing(E):	Projected(P):	
Irrigation	Status (E or P)	Irrigated Area (km ²)	Flow (m ³ /sec)

ECONOMIC ACTIVITIES:

Livestock (# head): (Swine) (Sheep) (Cattle) (Others) (Detail.) _____

Agriculture (Area farmed): (by types of crops-detail.): _____

Mining: (Type of minerals, reserves, amount exploited): _____

Agroindustry (types and production capacities): _____

Other industries and handicrafts (Detail): _____

APPENDIX I

REQUIREMENTS FOR A FORM FOR THE INVENTORY OF CAPACITIES FOR ENGINEERING AND PROJECT EXECUTION.

In reality, two forms would be necessary: one for construction and another for studies.

The forms will be processed by the official institution in charge of the energy sector in each country. The forms would basically contain questions for obtaining information with respect to the following:

- Experience in the development of SHPS and related fields.
- Number of professionals and technicians, of medium levels, and their qualifications by specializations related to SHPS.
- Magnitude and number of projects executed and being executed.
- Engineering capacities of the electricity institutions.
- Engineering capacities of other state entities.
- Engineering capacities of independent consultants.

In the form on construction, it is necessary to inquire about the capacity of the institutions with respect to equipment.

APPENDIX V

TERMS OF REFERENCE FOR AN ORIENTATION GUIDE FOR THE ELABORATION AND EVALUATION OF SHPS PROJECTS.

The guide should consider the scope of the stages of the studies and the corresponding methodology for its realization.

It would be useful to consider the following stages within the studies:

1. Identification of the resources and the demand. This is discussed in Appendix VII.
2. Preliminary Reconnaissance. For this stage, the objective and focus should be defined, along with the scope of this stage. Moreover, the methodologies of the following aspects should be studied:
 - Demand
 - Gauging of sources
 - Selection of possible sites for intake and powerhouse
 - Determination of possible fall
 - Prefeasibility

The studies which should be done will cover:

- General conditions of the area under study
- Gathering and evaluation of available information
- Estimate of electric energy demand
- Study of physical area
- Proposal and analysis of different alternatives
- Determination of costs indicative of development and projects

3. Feasibility. This stage should cover:

- Summary of previous studies
- Description and analysis of the available information and of the research done in this stage.

- Description of the alternatives considered with respect to the available sets of schemes.
- Description of the alternatives considered for designs at the level of feasibility for the elements of a SHPS, structure by structure.
- Comparison of the SHPS project with other alternative sources of electric energy supply.

4. Elaboration of SHPS Packages or Programs by means of the Establishment of Priorities and Standardization.

The utility of this stage lies in the establishment of a second instance of feasibility with respect to the reduction of investment costs, due to the following: grouping by geographical areas, equipment standardization, facility of negotiation of financing, possibility of obtaining better conditions for the acquisition of equipment, materials, and conditions for the execution of works.

5. Design up to Construction Plans.

The studies in this stage should cover:

- Detailed description of the component elements of the project and of the processes of the design
- Detailed description of the studies of the physical area and their implications for the design of the different elements.
- Detailed description of the selection criteria for the electro-mechanical equipment.
- Estimate of the costs on the basis of the amount of work (scheduled)
- Construction chronograms.

Two methodologies should be considered: a general one, which would contemplate a description of the fundamental characteristics of each stage, its focus as well as the way of realizing it, and a detailed methodology, which would indicate the steps to follow with respect to the different aspects to be considered in the studies. The scope of each one of the sub-divisions will have to be established according to the different power ranges to be installed. For the lowest power ranges, it would be possible to fuse or suppress stages, and this should be kept in mind for the document.

APPENDIX VI

TERMS OF REFERENCE FOR A MANUAL FOR THE ELABORATION OF SHPS ENGINEERING PROJECTS IN LATIN AMERICA

OBJECTIVE

To provide the engineers of the region with an instrument which permits them to give dimension to the different structures composing a SHPS; to calculate its schedules and amounts of work; to determine the cost of projects on the basis of a unit price analysis, up to a level permitting the initiation of the execution of the work; to elaborate the blueprints on the basis of which the construction can be done; and to make the comparisons corresponding to the feasibility study.

SCOPE

The manual should contain all of the elements necessary for the production of construction blueprints. In addition, for the purpose of illustrating the criteria for calculation, it would be useful for the manual to contemplate the fundamentals of elaboration for each one of the graphs or charts contained therein. This would permit the users of the manual to make rational use of the same.

In addition, the manual should contain a section dedicated to the most indicated procedures for the feasibility analysis.

The fundamental engineering aspects to be considered are the following:

- Estimate of the electric energy demand
- Selection of the location of a hydraulic power station.
- Treatment of the cartographic information and procedures for obtaining it. Minimum specifications.
- Dimensions of the different structures and equipment:
 1. Dam, wall, or diversion dam
 2. Intake and silt basin

3. Canals and tunnels with free surface
4. Tunnels and penstocks
5. Forebay
6. Powerhouse
 - a. Dimensions and area of the powerhouse as a function of electro-mechanical equipment.
 - b. Valves.
 - c. Selection of turbine and speed regulator
 - d. Selection of turbine-generator coupling
 - e. Selection of switchboard and instrumentation
 - f. Selection of transformer system and connections.
7. Transmission lines and networks.

Within the same focus, it would be extremely important to include a section on _____, in order to locate the SHPS intake and other structural components with the least risk. At the same time, it should contain a section with the most important aspects with regard to the hydrology of the basins with drainage areas smaller than 500 km². It is also especially interesting to have orientations with respect to the applications of the hydrology of mountainous areas.

The manual should consider recommendations for the design and application of non-conventional technologies.

With respect to equipment, orientations should be included for design, construction, and materials, according to the characteristics of the application.

It would be useful for the manual to be divided into parts devoted to different SHPS groups, as a function of the power to be installed, or at least to make reference to such groups within the text.

METHODOLOGY.

On the basis of the manuals existing in the different countries of the region, and using the aforementioned characteristics defined for the objective and scope as terms of reference, it would be useful to distribute the manual according to specialties. It is advisable to anticipate mid-point meetings of the specialists for an evaluation of the work before defining set goals.

APPENDIX VII

TERMS OF REFERENCE FOR A MANUAL FOR THE ELABORATION OF SMALL-SCALE HYDROENERGY RESOURCES AND THE RURAL ENERGY DEMAND IN LATIN AMERICA.

First Evaluation of SHPS Resources.

Objective.

This consists of elaborating a manual permitting the engineers and economists of the region to calculate the theoretically technically and economically feasible power ranges to be installed, with an estimate sufficient for the planning and programming stages. The results should also serve for the elaboration of specific projects.

Scope and Methodology.

The manual should contemplate two different kinds of evaluation:

First, the overall evaluation, which should be statistical, defining concentrations of theoretical potential, in terms of specific potential.

After establishing the criteria and methodologies for the global evaluation, the section corresponding to the systematic evaluation by lines and points will be elaborated.

Emphasis should be placed on the results of the global evaluation in their role within the development of the systematic inventory. In addition, it is useful to mention that the inventories done for the development and projects of higher capacity than the limits established for SHPS can be utilized.

The following aspects should be considered:

- Procedures for treating the cartographic and topographical information, or for complementing it in the cases where such information is lacking.
- Procedures for treating the hydrometeorological information.
- Procedures for estimating hydrometeorological variables, on the basis of generalized relationships and hydrogeological-geographical criteria.

- Procedures for evaluating theoretical global potential.
- Procedures for evaluating the potential by lines and points.
- Procedures for realizing the general geological studies.
- Procedures for establishing the alternatives for the different projects.
- Graphs and charts necessary for the rapid evaluation of amounts of work involved in the following structures:
 1. Dam, wall, or diversion dam
 2. Intake and silt basin
 3. Canals, tunnels, and penstocks
 4. Forebay
 5. Civil structure of the powerhouse
 6. Electro-mechanical equipment
- Procedures for making economic comparisons among alternatives.

On the basis of the work already done in the different countries of the region, and using these terms of reference, it is suggested that the already existing instruments be complemented and that those which are lacking be produced, in accordance with the enumeration of aspects described above.

Second Evaluation of Rural Energy Demand.

Objective.

This consists of elaborating a manual permitting the determination of the rural energy demand, at the level of localities, zones, or regions.

Scope.

The possible groupings of population nuclei must be kept in mind, according to socio-economic and geographical affinities, at the national and regional levels for each country. It is important to distinguish the breakdown of the demand in the manual, according to primary, secondary, and tertiary sectors.

In addition, it is important to consider the projections for future development in terms of an economy for the social sector.

Methodology.

This refers to a demographic analysis which considers the general situation of migrations from the country-side to the city, within the region.

Furthermore, it is important to refer to socio-economic studies with a view to the areas of interest, thus permitting a realistic perspective and the elaboration of a non-conventional focus, in terms which are framed within an economy for development. Within this frame of reference, it is very important for the methodology to take into account the fixing of elastic qualities permitting a plan for future development and complying with the general plans and programs of rural development.

The methodology should at first be indirect and should consider several alternatives with respect to the rates system.

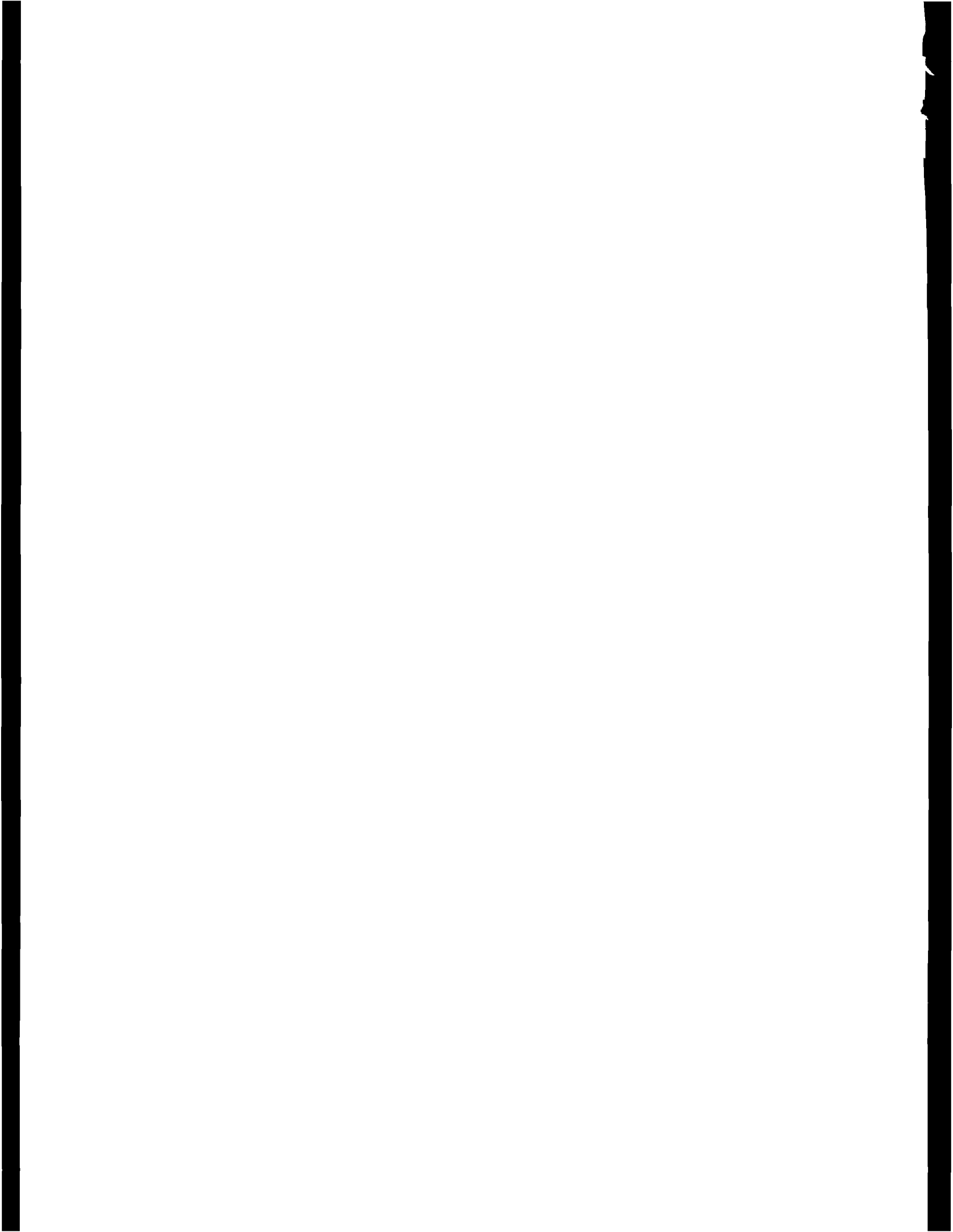

APPENDIX VIII

Identification of productive activities in isolated localities and the rural area, which could utilize the energy generated by the SHPS.

ACTIVITIES	INSTALLED POWER FOR CONSUMPTION (kW)
Carpentry shops	5 - 15
Bakeries	2 - 5
Artisanal activities	1 - 2
Small saw-mills	15 - 30
Sugar cane mill	10 - 20
Grain mill	3 - 20
Weaving	0.5 - 6
Coffee beneficiaries	5 - 30
Quarries	6 - 30
Ice-making	6 - 60
Irrigation pump	2 - 100
Brick-making	1 - 5
Lodging (20 guests)	2 - 5
Restaurant	1 - 2
Vegetable canning	5 - 20
Dairy products (butter, cheese)	2 - 10
Milk-processers (cooling and pre-evaporation)	5 - 20
Silos	3 - 5
Electrical and mechanical workshops (repairs)	5 - 15
Gasoline pumps	0.5 - 5

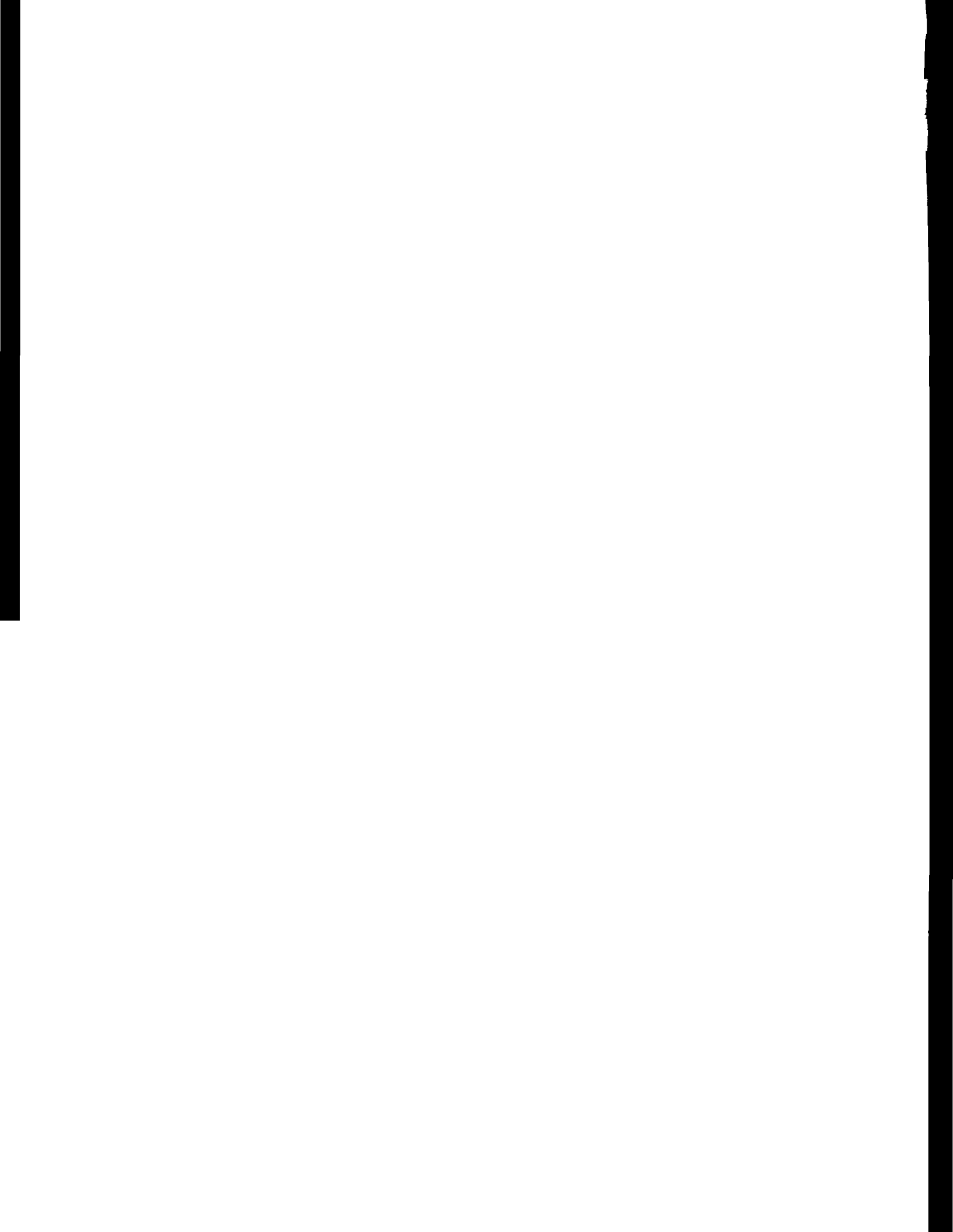

APPENDIX IX

REGIONAL COURSES FOR SPECIALIZATION IN SHPS

Objective.

To provide the region with a system of studies and professional formation in subjects related to the development of SHPS.

Scope and Methodology.

The programs should fall within the framework of a philosophy of reinforcing the progress obtained thus far in some of the countries of the region.

The following options should be considered:

For engineers: Training Courses, Post-graduate Courses, and improvements in the curricula of the different schools of engineering related to the development of SHPS.

For medium-level technicians: theoretical aspects within the same program as that for the engineers and sub-regional and/or in-service training.

The courses will be developed jointly among the specialties, and the evaluations will be differentiated according to these, with emphasis on the preparation of monographs by interdisciplinary teams.

APPROXIMATE CURRICULA.

1. Training Courses for Engineers:
 - Hydraulics and hydrology.
 - General hydraulics.
 - Geographical hydrology and hydrometry.
 - River hydraulics
 - Small-scale hydroelectric utilization.
 - Hydraulic structures.
 - Fundamentals of geology, geomorphology, geotechnics, and ecology.
 - Development of multipurpose hydro resources.

- Economy in hydro resource projects.
- Administration and conservation of basin resources.
- Elaboration of investment projects, applied to SHPS.
- Elements of sociology and psychology.
- Methodology of the technology.
- Composing reports.
- Non-conventional materials, design, and construction.
- Electro-mechanical utilization.
- Application of systems of regulation and control.
- Electrical materials.
- Utilization of electric machinery.
- Hydraulic machinery.
- Physical models and similarity.
- Electrical installations.
- Medium- and high-tension transmission lines.

2. Post-graduate Courses:

- Machinery laboratory and electrical installations.
- Applied mathematics.
- Fluids mechanics.
- General hydraulics.
- Mechanical design applied to SHPS equipment.
- Geographical, physical, estocastic hydrology and hydrometry.
- River hydraulics
- Hydraulics laboratory.
- Small-scale use of hydro power.
- Hydraulic machinery laboratory.
- Hydraulic structures.
- Fundamentals of geology, geomorphology, geotechnics, and ecology.
- Development of multipurpose hydro resources.
- Adminstration and conservation of basin resources.
- Soils and mineral mechanics laboratory.
- Methodology for technology and approximation to design.
- Composing reports.
- Non-conventional materials, design and construction for civil engineering.
- Hydraulic machinery.

- Electric machinery.
- Technological research and development.
- Operation research.
- Principles of design and construction for generators and transformers.
- Elements of sociology and psychology.
- Properties and selection of electro-mechanical equipment.
- Applied metallurgy, for the design and construction of electro-mechanical equipment for SHPS.

3. Improvement of Curricula:

The different programs of the region should be studied for the purpose of proposing concrete modifications or improvements in:

- Automatic control.
- Applied electronics, for the power system and the automatic control.
- Electrical materials.
- Elaboration and evaluation of investment projects applied to SHPS.
- Hydraulic utilization.

4. Course on Theoretical Aspects for Medium-level Technicians:

- Fundamental applied mathematics.
- Topography.
- Hydrometry.
- Laboratory testing.
- Fundamental hydraulics.
- Non-conventional construction materials.
- Processes for the manufacturing and repair of equipment (welding, assembly, etc.)
- Materials (for civil, electrical, and mechanical construction)
- Interpretation of blueprints.
- Administration and conservation.
- Construction methods.
- Elements of programming and interpretation of graphs.
- Elements of sociology and psychology.
- Composing reports.
- Hydraulic machinery (application, assembly, and maintenance).

- Electrical installations.
- Electric machinery (application, assembly, and maintenance).

As a second part of the training for medium-level technicians, in-service training or courses in sub-regional centers is proposed. It is vitally important to coordinate the engineering program with the institutions of higher learning in the region, and that of the technicians, with the labor institutions represented in the region.

APPENDIX X

GUIDELINES FOR THE OPERATORS TRAINING COURSE.

Objective.

To generate institutionalized schemes oriented towards the training of SHPS operators of rural origin.

Methodology and Scopes.

In accordance with the experiences of countries in the region, the conclusion is that the training courses should be based on a pilot plant, adapted as a Field School, during the first stage, and in the second, should be developed in existing power plants.

The first stage of the course will have a theoretical-practical character adapted to the educational levels of the operators; it would be expected that the rural operators would have less than a primary school education. The duration of the course would be three months, and it would include the following subjects:

- Basic sciences.
- Elemental principles of SHPS functioning and their equipment.
- Operation of SHPS and interpretation of operators manual.
- Principles and methods for preventive SHPS maintenance.
- Maintenance and repair of civil structures and installations.
- Maintenance and minor repairs of mechanical equipment.
- Maintenance and minor repairs of electrical equipment.
- Identification of mechanical and electrical failures.
- Elements of interpretation of blueprints and diagrams.
- Elements of electrical installations.
- Reading of instruments.
- Bench mechanics.
- Operational safety.
- Elements of administration.

The second stage will be of an essentially practical nature, consisting of the training of the operators who have successfully completed the first stage and who have worked in an existing power station for a two-month period, under the supervision of a qualified operator.

